



160 Series Sand Filter

Operation & Maintenance Guide



R:9/14/1818

INSTALLATION INSTRUCTIONS

The filter shall be installed, plumb and level. Run water in tank for leveling each layer of filter media except top layer of fine sand. This layer of fine sand can be leveled sufficiently with a long handled rake. Fine sand comes slightly above manhole opening. Leave enough sand near opening to fill the top layer out after manhole cover has been installed. The first time the filter is backwashed, the top of the sand will become level.

Close manway cover by tightening the manhole knobs down on the manway yokes. The manway gasket is aided in sealing tightly by the pressure in the tank. During start-up the gasket may leak slightly but it should come to a tight seal once operating pressure is reached. After reaching operating pressure tighten the manway knobs again to insure a seal through subsequent shut-downs. If the manway gasket leaks at operating pressure, gradually close the valve on the filter effluent flange (or any valve in the line after the filter) to increase the pressure in the filter tank. This excess pressure in the filter tank will aid in final sealing of the manway gasket. Again, hand tighten the knobs of the manway yokes after reaching the highest pressure obtainable.

OPERATING INSTRUCTIONS

Install all face piping including valves, pressure gauges, sight glass, and circulating pump as shown on drawings, single and dual tank systems (see pages 4 and 5). To allow venting of air from the tanks during start-up and operation, the air relief connections on the front and top of the tank should be piped to a low pressure point in the filter system or to a waste line. Piping this to a surge tank or gutter line will save this water which is chemically treated and filtered. We suggest this line be rigid PVC or flexible tubing. A manual shut-off valve should be mounted on each tank. This valve should be open during operation, closed on shut-down. Automatic air relief valves are also available for air venting.

FILTERS SHOULD BE BACKWASHED WHEN THE FILTER PRESSURE DIFFERENTIAL EXCEEDS 10 - 12 PSI.

FILTER CYCLE:

Open valves V1 and V3 and close valves V2 and V4. Start pump.

Shut off pump, close valves V1 and V3 and open valve V2. Start pump and open valve V4 slowly. The time from start to full open should be at least 3.0 seconds. Do not exceed backwash flow rate shown on tank data plate. Continue BAC shing until sigh flow indicator shows clear. This should be approximately five (5) minutes. At completion of backwash, shut off pump and allow filter beds to settle three (3) minutes before starting pump on filter cycle.

THREE OR MORE TANK SYSTEMS

Generally, some form of backwash flow rate control is required on multiple tank systems to limit backwash flow to that required for one tank. Tanks are backwashed one at a time, in sequence, according to the above procedure. Attempts to backwash all tanks simultaneously will result in excessive water flowing through the first tank, resulting in disruption of the sand bed and filter failure. It is not possible to write instructions for the numerous multiple tank configurations that can be designed. We suggest a piping layout be sent to our office for comments prior to installation.

MER-MADE FILTER HIGH RATE SAND FILTER INTERNAL ASSEMBLY DRAWING AND PARTS LIST MODELS 160-109 AND 160-133

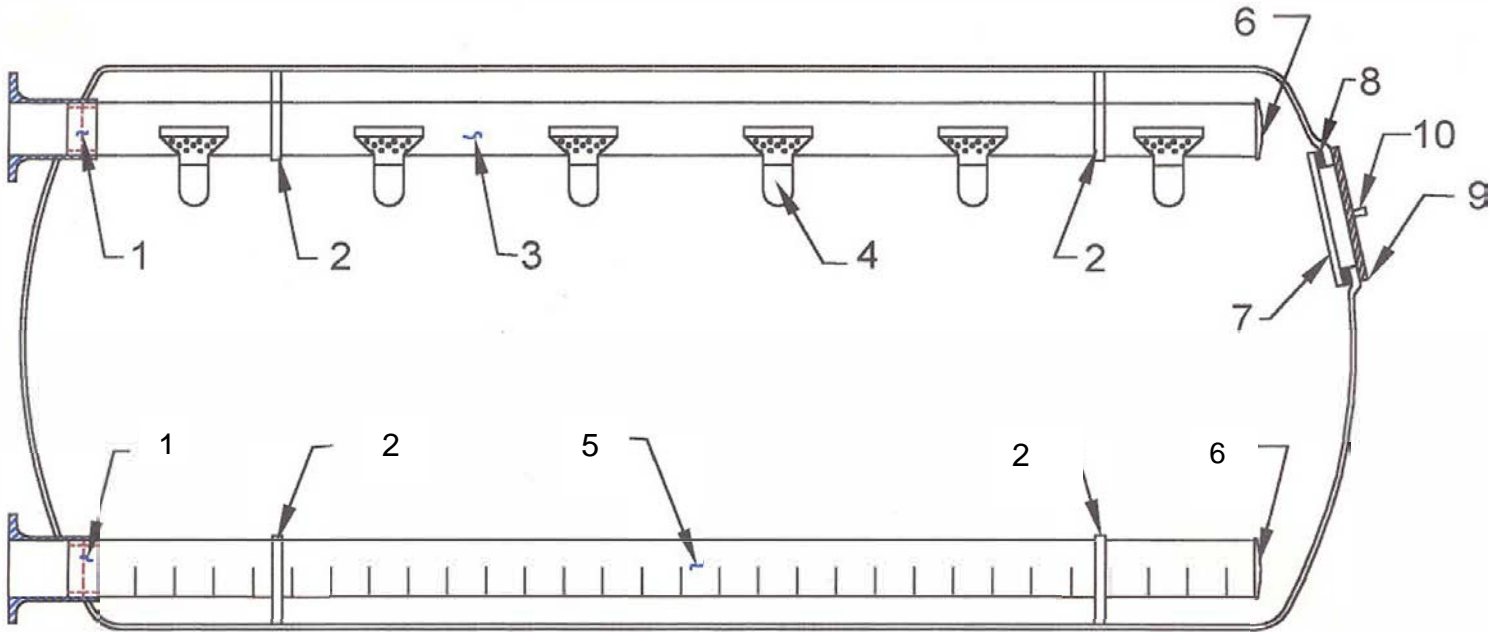

PARTS LIST

- | | |
|--|--|
| <ul style="list-style-type: none"> 1. 6" PVC COUPLING, SCH. 80 2. STAINLESS STEEL CLAMP 3. 6" PVC INLET PIPE, SCH. 80 4. PVC INLET LATERAL ASSEMBLY 5. 6" PVC UNDERDRAIN COLLECTOR, SCH. 40 | <ul style="list-style-type: none"> 6. 6" PVC CAP, SCH. 80, SLIP 7. 14" x 18" MANHOLE COVER 8. MANHOLE COVER GASKET 9. MANHOLE YOKE 10. KNOB |
|--|--|

FILTER MEDIA	BAGS OF 100 LB. FILTER MEDIA REQUIRED BY MODEL	
	160-109	160-133
BOTTOM LAYER 1/4" X 1/2" STONE	14	17
SECOND LAYER 1/8" X 1/4" STONE	10	13
THIRD LAYER 6-20 SAND	13	16
TOP LAYER 20-30 SAND	53	65
TOTAL BAGS	90	111

MER-MADE FILTER HIGH RATE SAND FILTER INTERNAL ASSEMBLY DRAWING AND PARTS LIST MODELS 160-157, 160-t81, AND 160-205

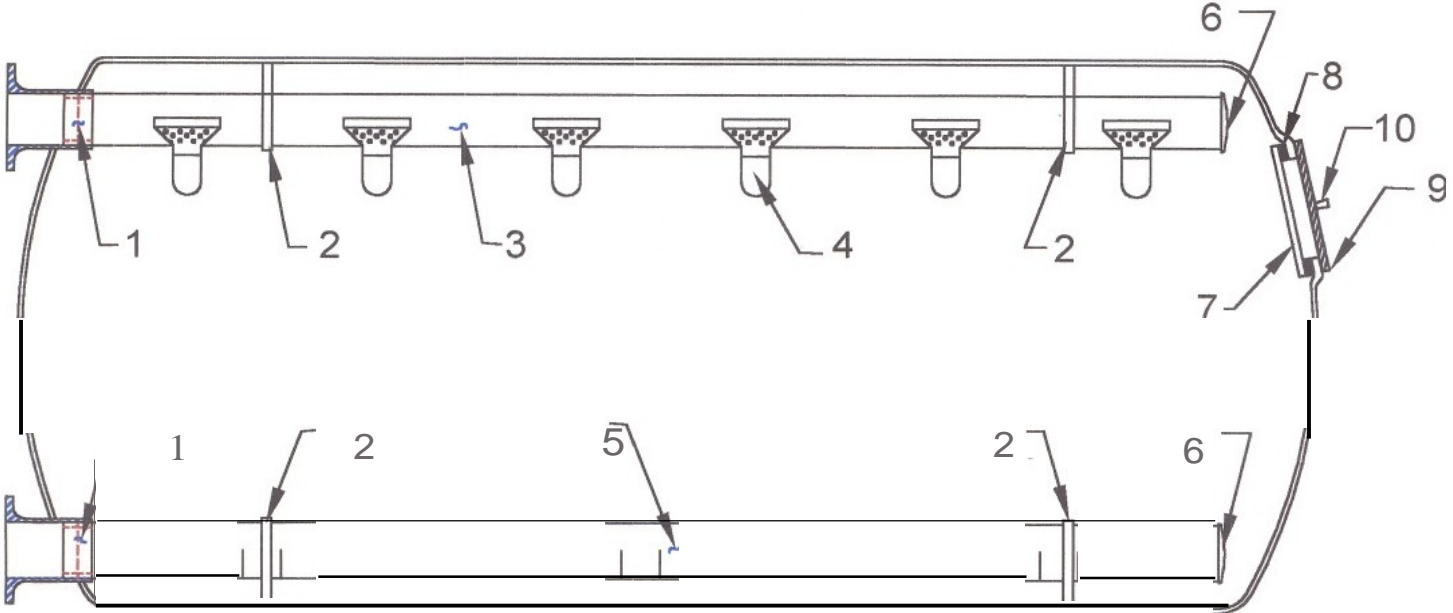

PARTS LIST

- | | |
|--|--|
| <ul style="list-style-type: none"> 1. 8" PVC COUPLING, SCH. 80 2. STAINLESS STEEL CLAMP 3. 8" PVC INLET PIPE, SCH.80 4. PVC INLET LATERAL ASSEMBLY 5. 8" PVC UNDERDRAIN COLLECTOR, SCH.40 | <ul style="list-style-type: none"> 6. 8" PVC CAP, SCH. 80, SLIP 7. 14" x 18" MANHOLE COVER 8. MANHOLE COVER GASKET 9. MANHOLE YOKE 10. KNOB |
|--|--|

FILTER MEDIA	BAGS OF 100 LB. FILTER MEDIA REQUIRED BY MODEL		
	160-157	160-181	160-205
BOTTOM LAYER 1/4" X 1/2" STONE	19	22	25
SECOND LAYER 1/8" X 1/4" STONE	15	18	20
THIRD LAYER 6-20 SAND	18	21	24
TOP LAYER 20-30 SAND	77	89	101

SINGLE TANK

HIGH RATE SAND FILTER

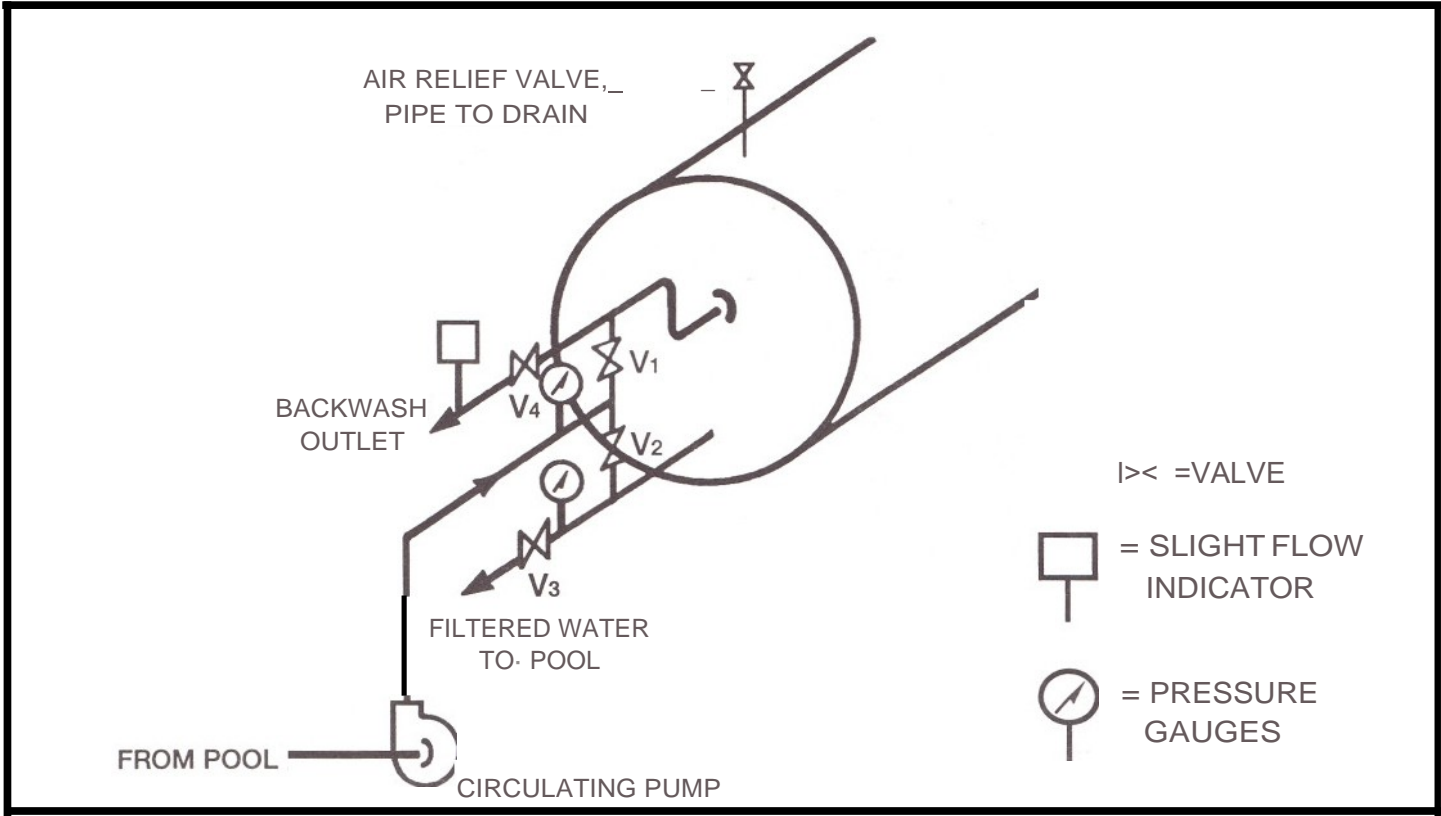

FILTER OPERATION:

STEPS	FLOW	VALVE POSITION				TIME
		V1	V2	V3	V4	
FILTER	* 5-20 GPM/F-r	0	C	0	C	-
BACKWASH	* 15 GPM/F" J2	C	0	C	0	APPROX. 3 MIN.

HYDRAULIC DATA:

FILTER MODEL	FILTER AREA SQ. FT.	BACKWASH RATE GPM
160-109	41.6	624
160-133	51.6	774
160-157	61.6	924
160-181	71.6	1074
160-205	81.6	1224

* MULTIPLY BY FILTER RATED AREA FOR FLOW IN GPM

0 = VALVE OPEN

C = VALVE CLOSED

DOUBLE TANK

HIGH RATE SAND FILTER

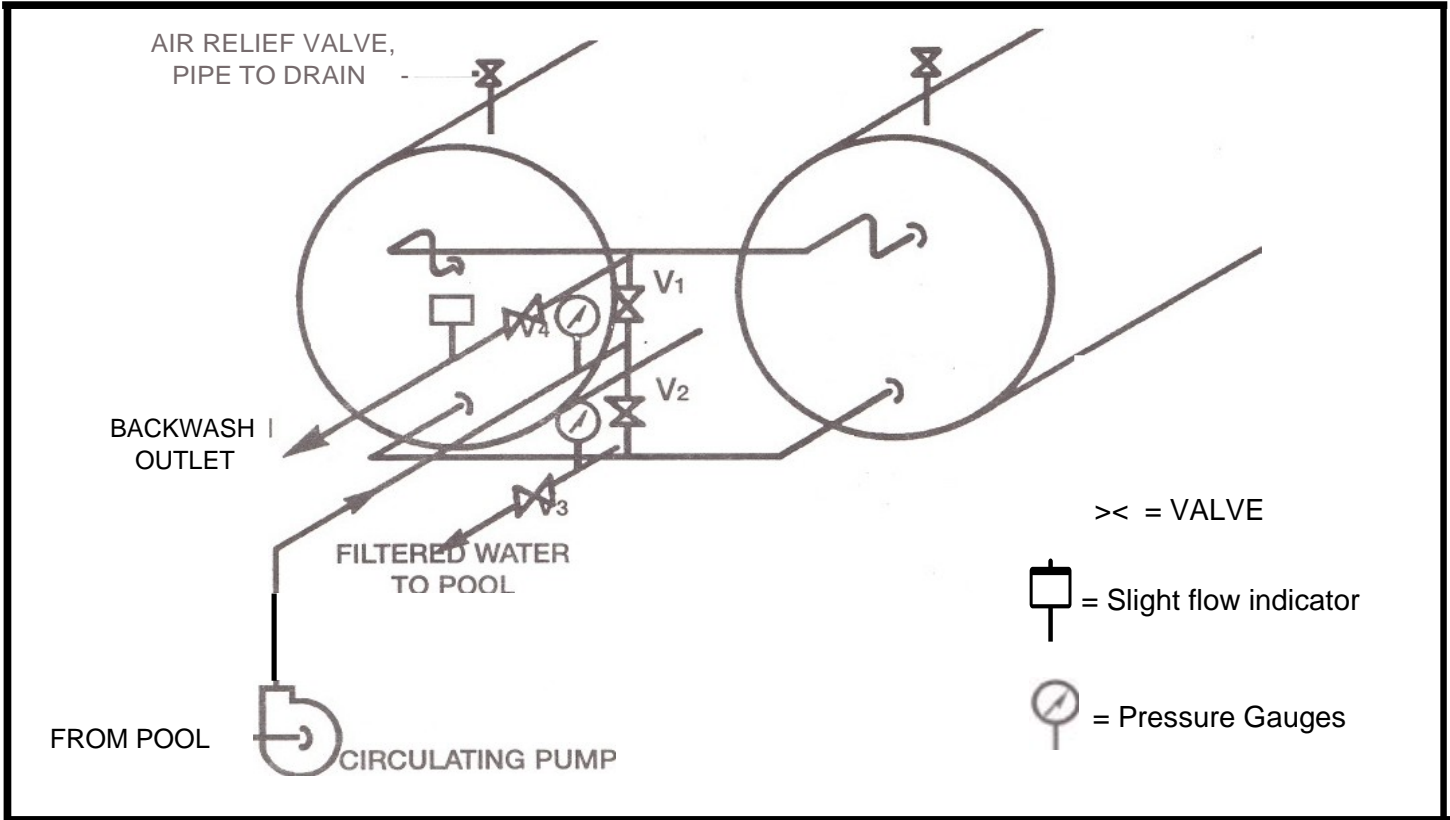

FILTER OPERATION:

HYDRAULIC DATA:

STEPS	FLOW	VALVE POSITION				TIME
		V1	V2	V3	V4	
FILTER	* 5-20 GPM/Ff	0	.C	0	C	-
BACKWASH	* 15 GPM/Fr	C	0	C	0	APPROX. 3 MIN.

FILTER MODEL	FILTER AREA SQ. FT.	BACKWASH RATE GPM
160-109	83.2	1248
160-133	103.2	1548
160-157	123.2	1848
160-181	143.2	2148
160-205	163.2	2448

* MULTIPLY BY TOTAL FILTER RATED AREA FOR FLOW IN GPM
(TOTAL FILTER AREA = 2 X TANK AREA)

0 = VALVE OPEN

C = VALVE CLOSED

HEAD LOSS

MER-MADE FILTER

160 SERIES SAND FILTER

MODEL 160-109
MODEL 160-133
MODEL 160-157

MODEL 160-181
MODEL 160-205

