

- NOTES**
1. STRAINER BODY: FIBERGLASS CONSTRUCTION USING ISOPHTHALIC POLYESTER RESIN AND A .100" THK. CORROSION LINER USING ONE LAYER C GLASS AND TWO LAYERS CHOPPED STRAND MAT.
 2. LID: CLEAR ACRYLIC
 3. TOGGLE BOLTS: STAINLESS STEEL
 4. HAND KNOBS: ABS WITH BRASS INSERTS
 5. O-RING: ETHYLENE PROPYLENE
 6. BASKET: 316 STAINLESS STEEL WEDGE WIRE, 3/16" SQ. OPENING

INLET AND OUTLET FLANGES SHALL HAVE 150# ANSI STANDARD DRILL PATTERNS

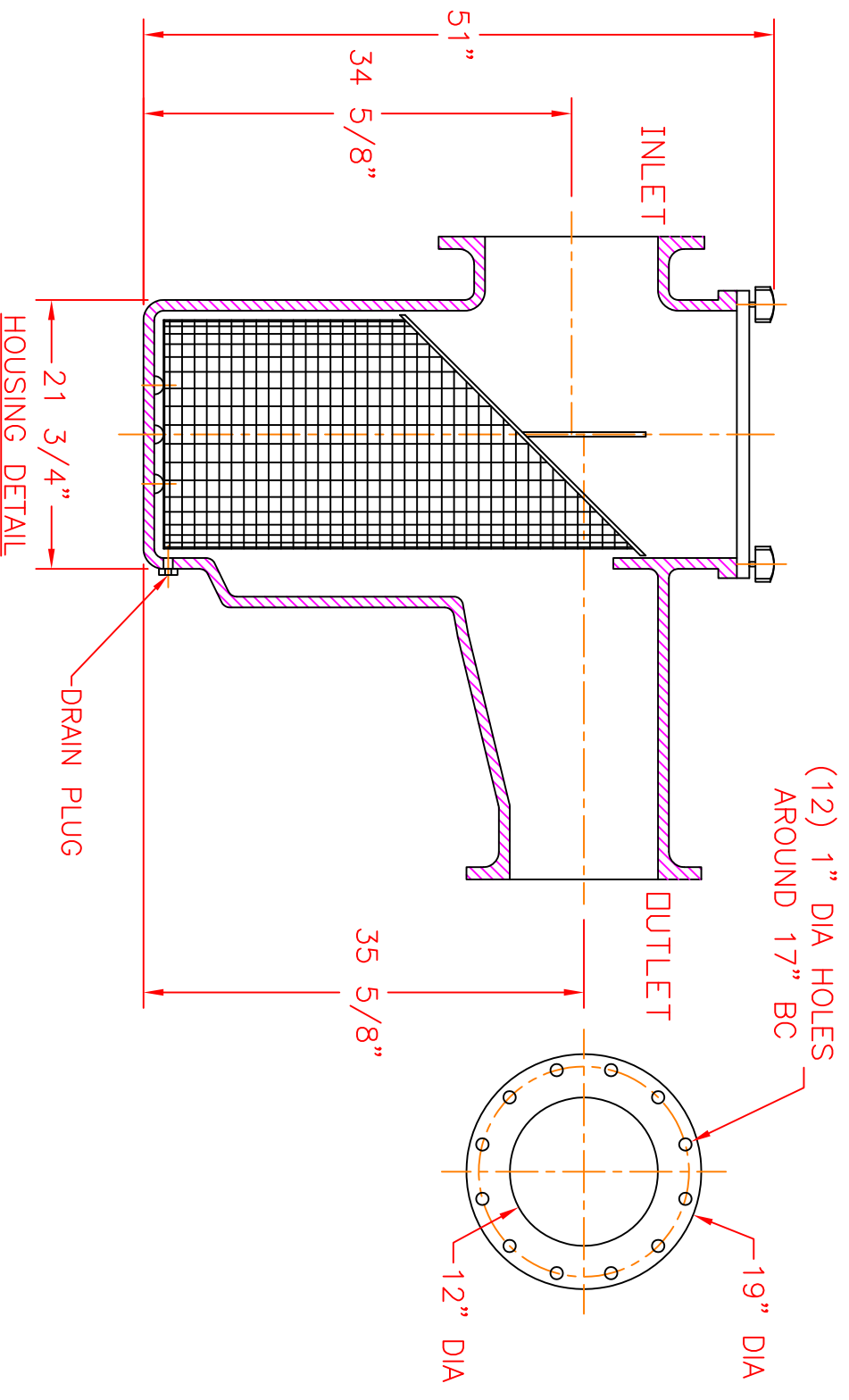
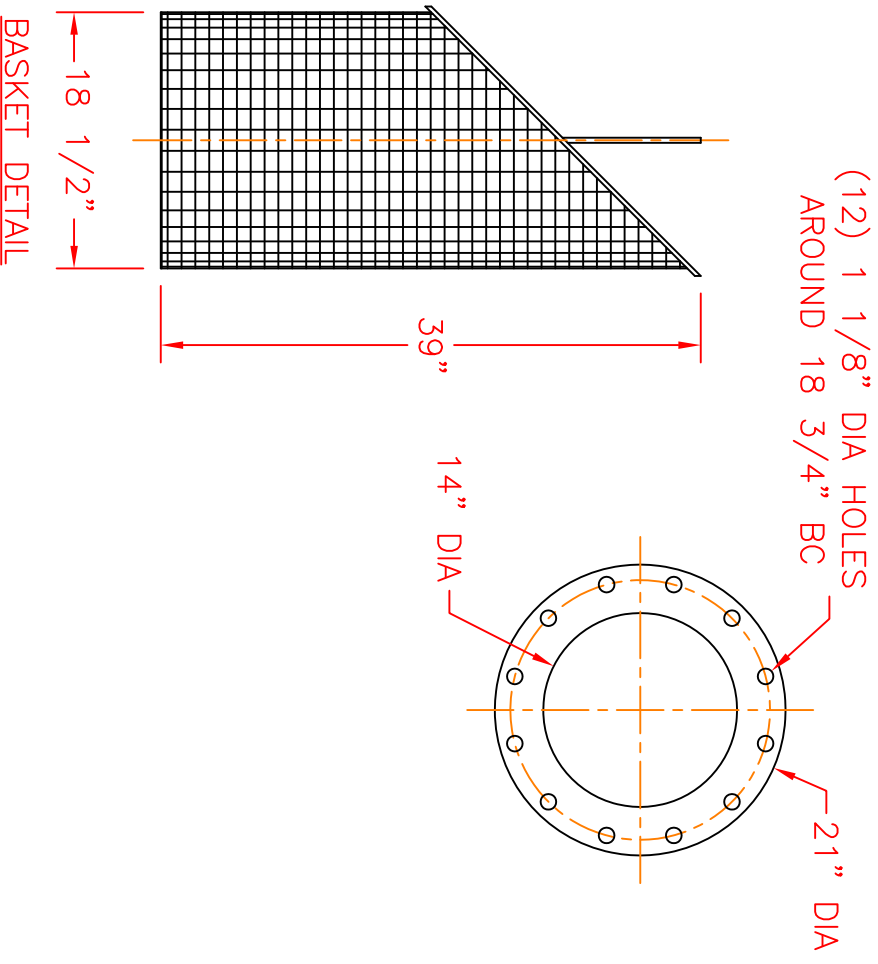
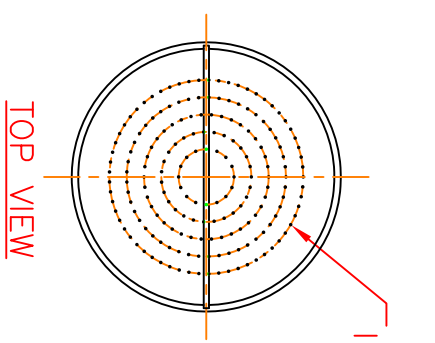
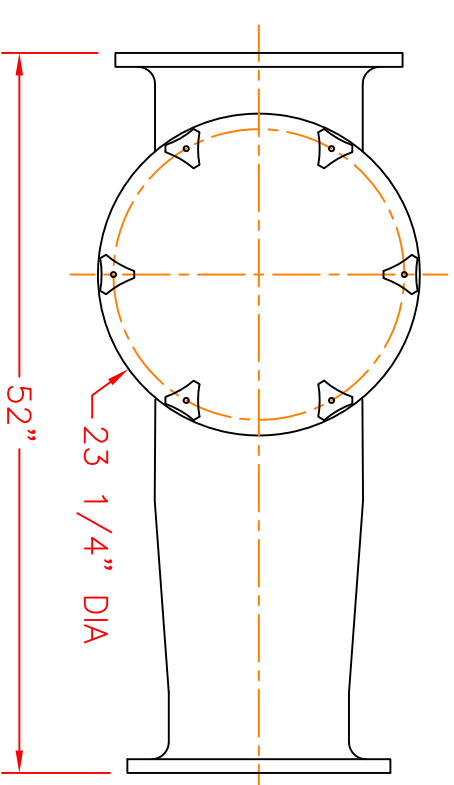

CERTIFIED FOR PRODUCTION

BY: _____ DATE: _____

MER-MADE, INC.

THIS DRAWING CONTAINS INFORMATION PROPRIETARY TO MER-MADE FILTER INCORPORATED. IT IS SLIGHTED IN CONFIDENCE AND IS TO BE USED SOLELY FOR THE PURPOSE FOR WHICH IT IS FURNISHED AND IS TO BE RETURNED UPON COMPLETION OF THE PROJECT. NO PARTS OR INFORMATION FROM THIS DRAWING IS TO BE TRANSMITTED, DISCLOSED, OR USED OTHERWISE IN WHOLE OR IN PART WITHOUT THE WRITTEN AUTHORIZATION OF MER-MADE FILTER INCORPORATED.

TOLERANCES UNLESS OTHERWISE SPECIFIED

MACHINED DIMENSIONS:

X.X ±.020 FINISH: 125/
X.XX ±.010 ANGLES: ±Z
X.XXX ±.005 RADII: ±.03

FRACTIONAL DIMENSIONS:

1/X ± 1/8

REMOVE ALL BURRS AND BREAK ALL SHARP EDGES: .016 x 45°

REV	DESCRIPTION	DATE	SCALE	NTS	DATE	Sheet	OF
						1	1

MER-MADE		PO BOX 306
		DENMARK, SC 29042
		P:803-793-4263 F:803-793-4265
14" X 12" FO SERIES ECCENTRIC REDUCING BASKET STRAINER		
SIZE	DWN BY: SUV	DWG NO. M-0131
B	CHK BY:	
REV		RO