

NOTES

1. STRAINER BODY: FIBERGLASS CONSTRUCTION USING ISOPHTHALIC POLYESTER RESIN AND A .100" THK. CORROSION LINER USING ONE LAYER C GLASS AND TWO LAYERS CHOPPED STRAND MAT.
2. LID: FRP WITH ACRYLIC VIEWPORT
3. TOGGLE BOLTS: STAINLESS STEEL
4. HAND KNOBS: ABS WITH BRASS INSERTS
5. O-RING: ETHYLENE PROPYLENE
6. BASKET: 316 STAINLESS STEEL WEDGE WIRE, 3/16" SQUARE OPENING

-INLET AND OUTLET FLANGES SHALL HAVE 150# ANSI STANDARD DRILL PATTERNS

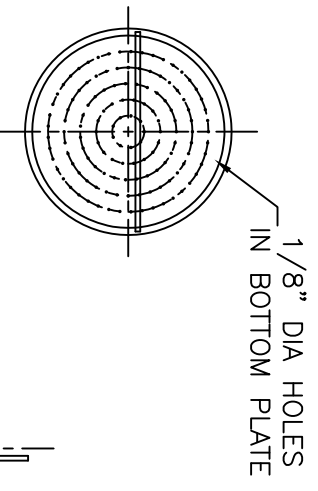
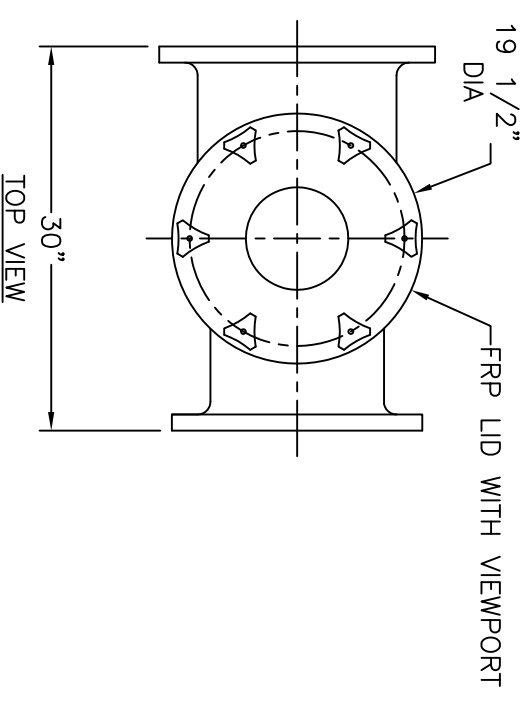

TOP VIEW

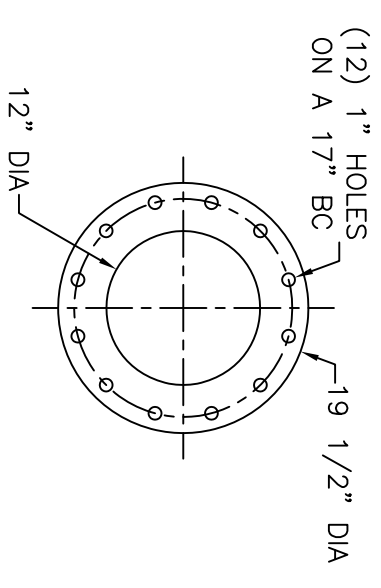
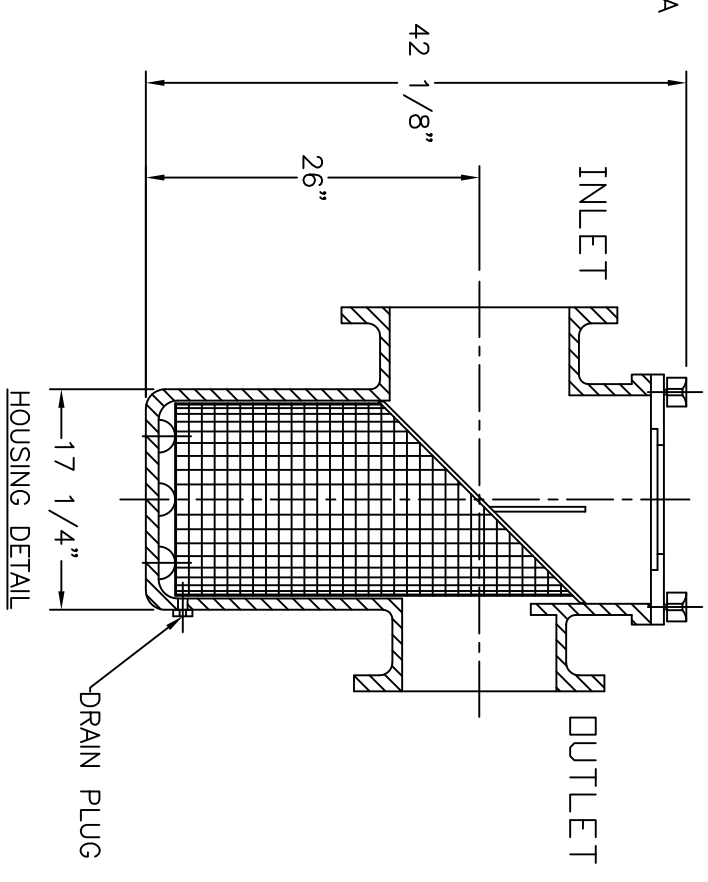
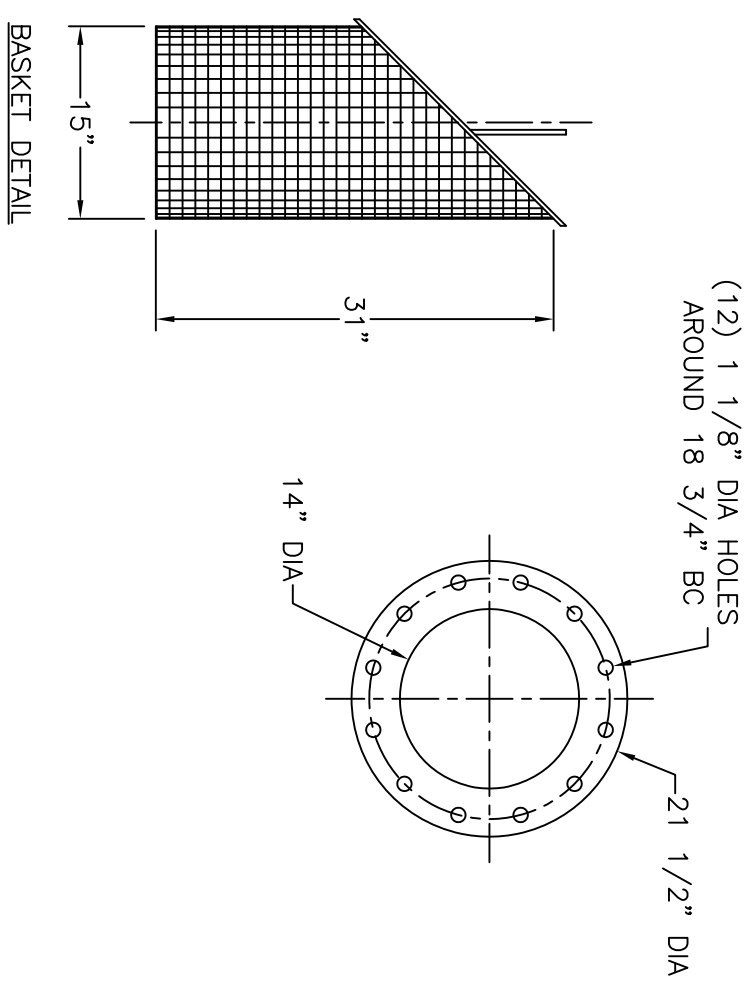

CERTIFIED FOR PRODUCTION

BY: _____ DATE: _____

MER-MADE, INC.

THIS DRAWING CONTAINS INFORMATION PROPRIETARY TO MER-MADE FILTER INCORPORATED. IT IS SUBMITTED IN CONFIDENCE AND IS TO BE RETURNED UPON REQUEST. THIS DRAWING AND SPECIFICATIONS ARE NOT TO BE REPRODUCED, COPIED, OR TRANSMITTED IN ANY FORM OR BY ANY MEANS WITHOUT THE WRITTEN AUTHORIZATION OF MER-MADE FILTER INCORPORATED.

TOLERANCES UNLESS OTHERWISE SPECIFIED

MACHINED DIMENSIONS:

XX ±.020 FINISH: 125/
XXX ±.010 ANGLES: ±2°
X:XXX ±.005 RADII: ±.05

FRACTIONAL DIMENSIONS:

1/X ± 1/8

REMOVE ALL BURRS AND BREAK ALL SHARP EDGES: .016 x 45°

REV	DESCRIPTION	DATE

MER-MADE

PO BOX 306
DENMARK, SC 29042
P:803-793-4263 F:803-793-4265

14" X 12" T-STYLE STANDARD
REDUCING BASKET STRAINER

SIZE: B DWN BY: SJV DWG NO. M-0200

SCALE: NTS DATE: 05/21/20 Sheet: 1 OF 1

REV R0