

- NOTES**
1. STRAINER BODY: FIBERGLASS CONSTRUCTION USING ISOPHTHALIC POLYESTER RESIN AND A .100" CORROSION LINER USING ONE LAYER C-GLASS AND TWO LAYERS CHOPPED STRAND MAT.
 2. LID: FRP WITH ACRYLIC VIEWPORT
 3. TOGGLE BOLTS: STAINLESS STEEL
 4. HAND KNOBS: FRP WITH STAINLESS STEEL INSERTS
 5. O-RING: ETHYLENE PROPYLENE
 6. BASKET: 316 STAINLESS STEEL WEDGE WIRE, 3/16" SQ. OPENING

INLET AND OUTLET FLANGES SHALL HAVE 150# ANSI STANDARD DRILL PATTERNS.

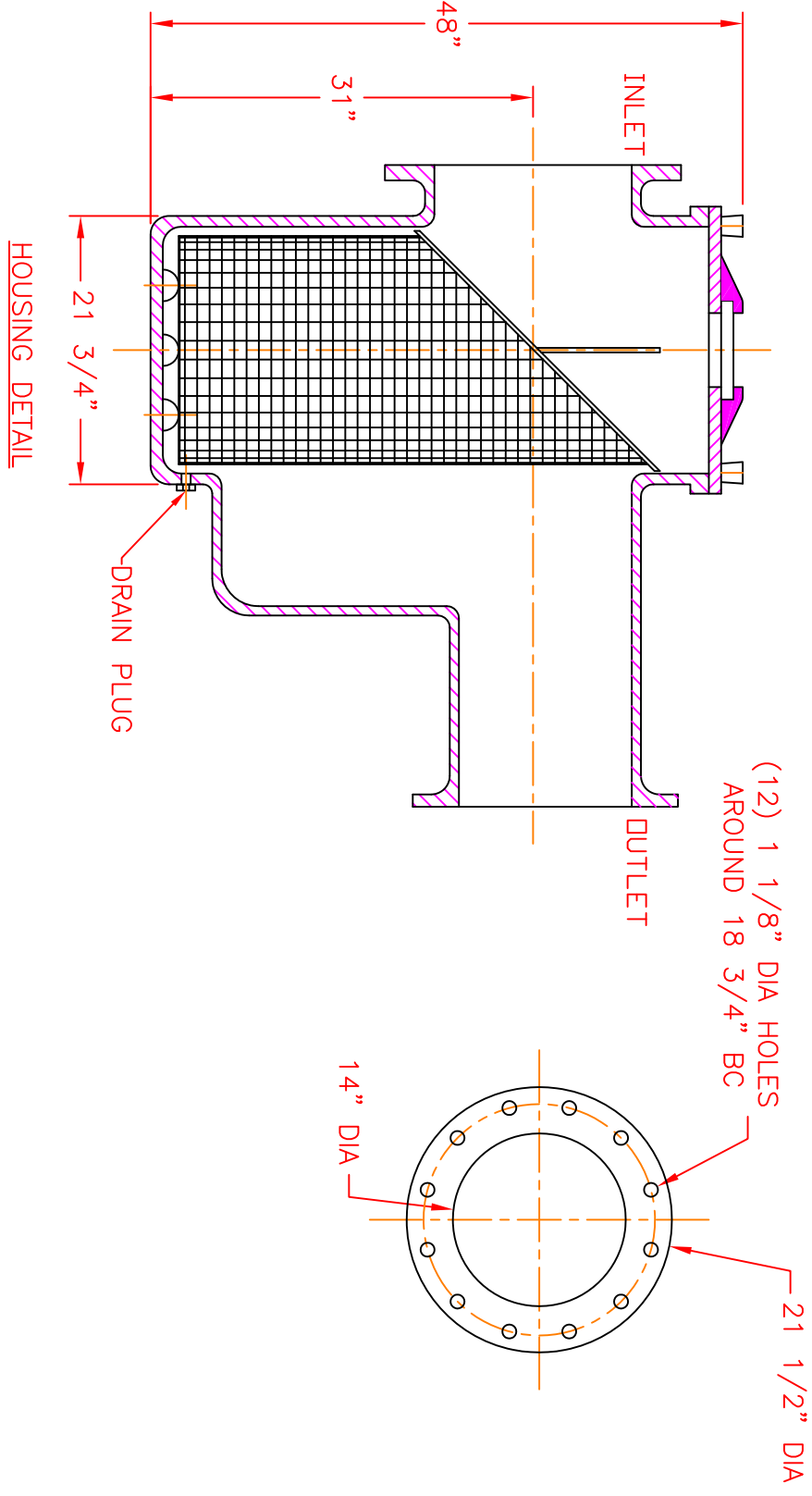
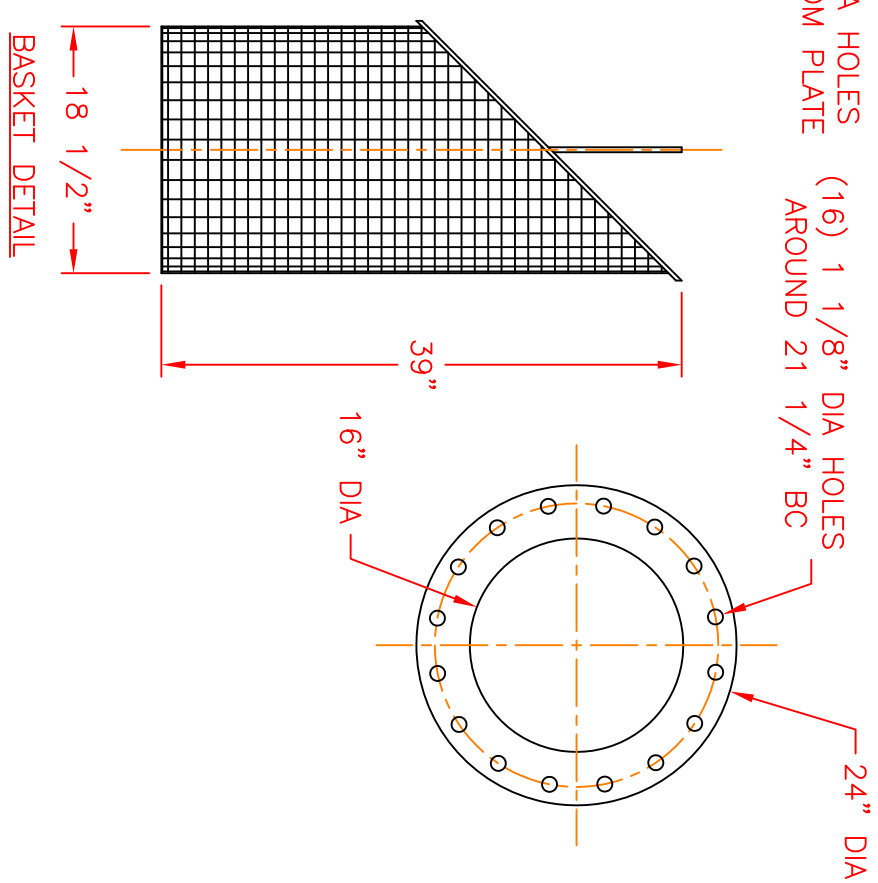
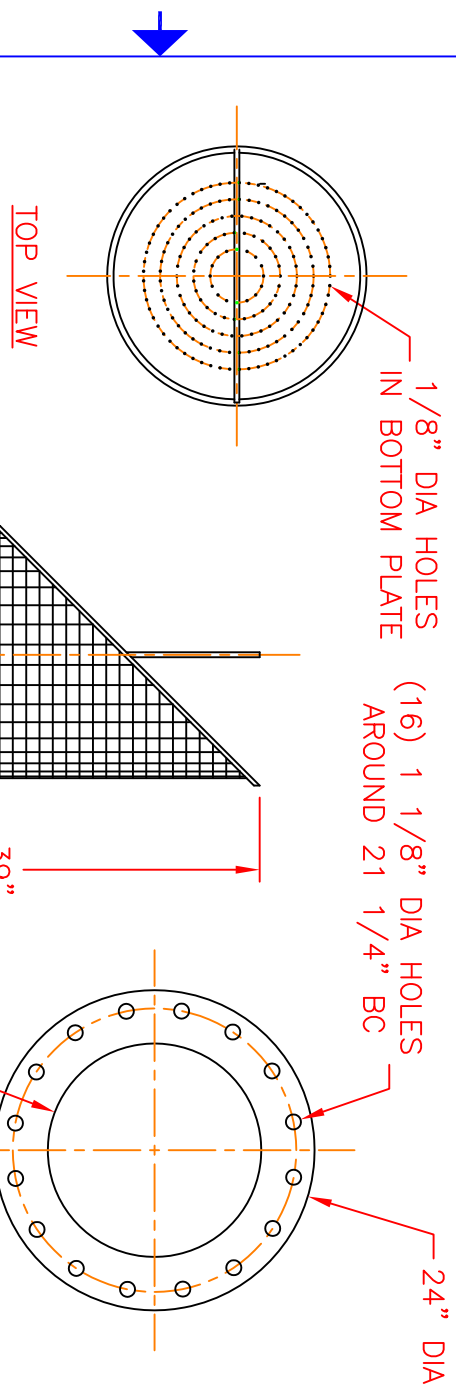
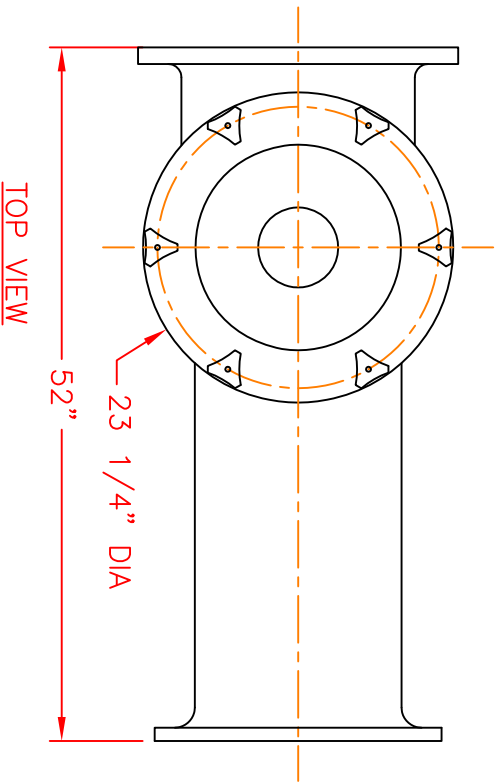

CERTIFIED FOR PRODUCTION

BY: _____ DATE: _____

LEEM FILTRATION, INC.

THIS DRAWING CONTAINS INFORMATION PROPRIETARY TO LEEM FILTRATION INCORPORATED. IT IS SLANTED IN CONFIDENCE AND IS TO BE RETURNED UPON REQUEST. THIS DRAWING IS NOT TO BE REPRODUCED, TRANSMITTED, DISCLOSED, OR USED OTHERWISE IN WHOLE OR IN PART WITHOUT THE WRITTEN AUTHORIZATION OF LEEM FILTRATION INCORPORATED.

TOLERANCES UNLESS OTHERWISE SPECIFIED

MACHINED DIMENSIONS:

X.X ±.020 FINISH: 125/
 X.XX ±.010 ANGLES: ±.2°
 X.XXX ±.005 RADII: ±.03

FRACTIONAL DIMENSIONS:

1/X ± 1/8

REMOVE ALL BURRS AND BREAK ALL SHARP EDGES: .016 x 45°

REV	DESCRIPTION	DATE

MERSMADE PO BOX 306
 DENMARK, SC 29042
 P:803-793-4263 F:803-793-4332

16" X 14" REDUCING
 FO SERIES BASKET STRAINER

SIZE: B DWN BY: SVJ DWG NO. FO-16X14-STR
 CHK BY: _____

SCALE: NTS DATE: 03/28/18 Sheet: 1 OF 1

REV
 STRIP RED