

NOTES

1. STRAINER BODY: FIBERGLASS CONSTRUCTION USING ISOPHTHALIC POLYESTER RESIN AND A .100" THK. CORROSION LINER USING ONE LAYER C GLASS AND TWO LAYERS CHOPPED STRAND MAT.
2. LID: FRP WITH ACRYLIC VIEWPORT
3. TOGGLE BOLTS: STAINLESS STEEL
4. HAND KNOBS: ABS WITH BRASS INSERTS
5. O-RING: ETHYLENE PROPYLENE
6. BASKET: 316 STAINLESS STEEL WEDGE WIRE, 3/16" SQUARE OPENING

-INLET AND OUTLET FLANGES SHALL HAVE 150# ANSI STANDARD DRILL PATTERNS

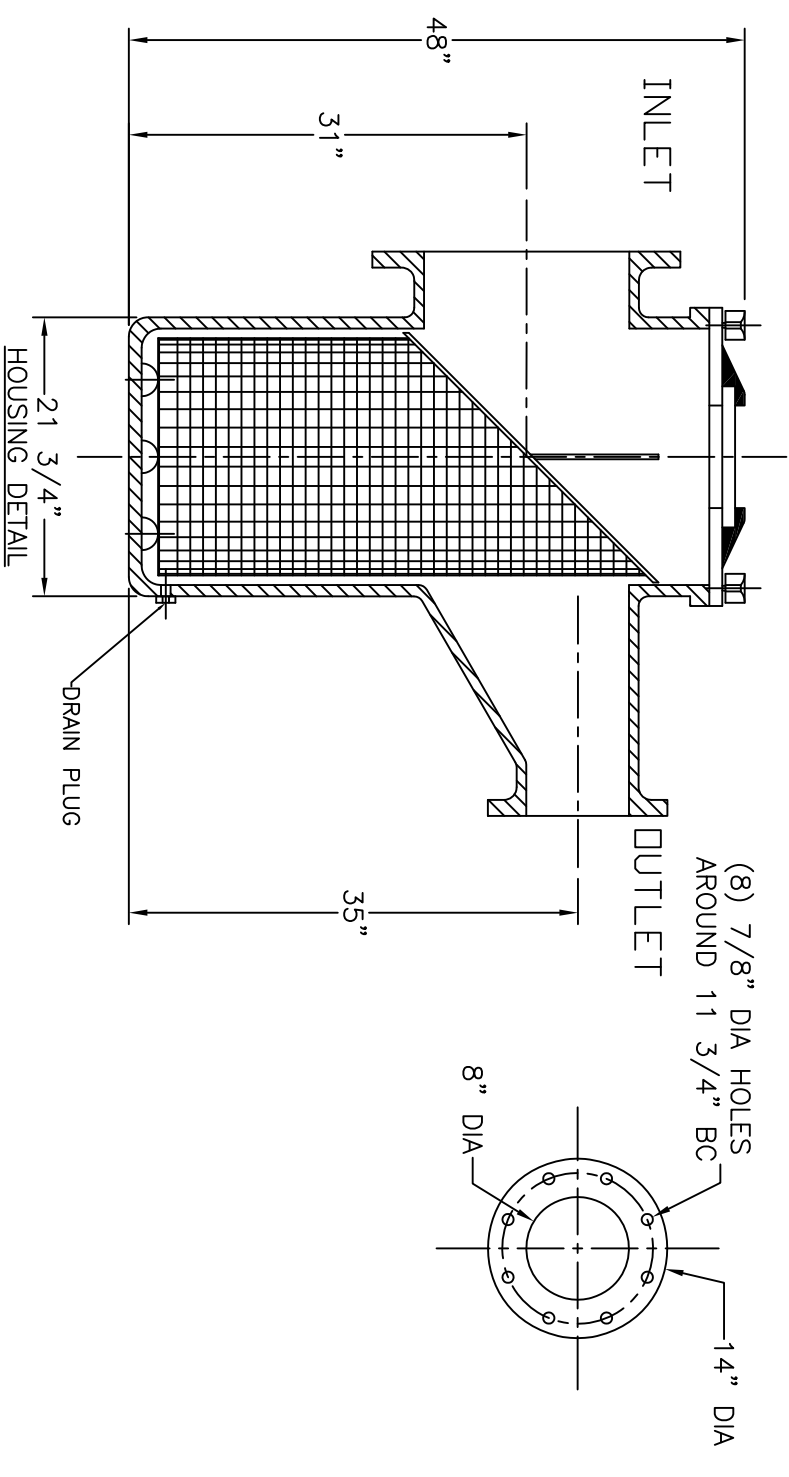
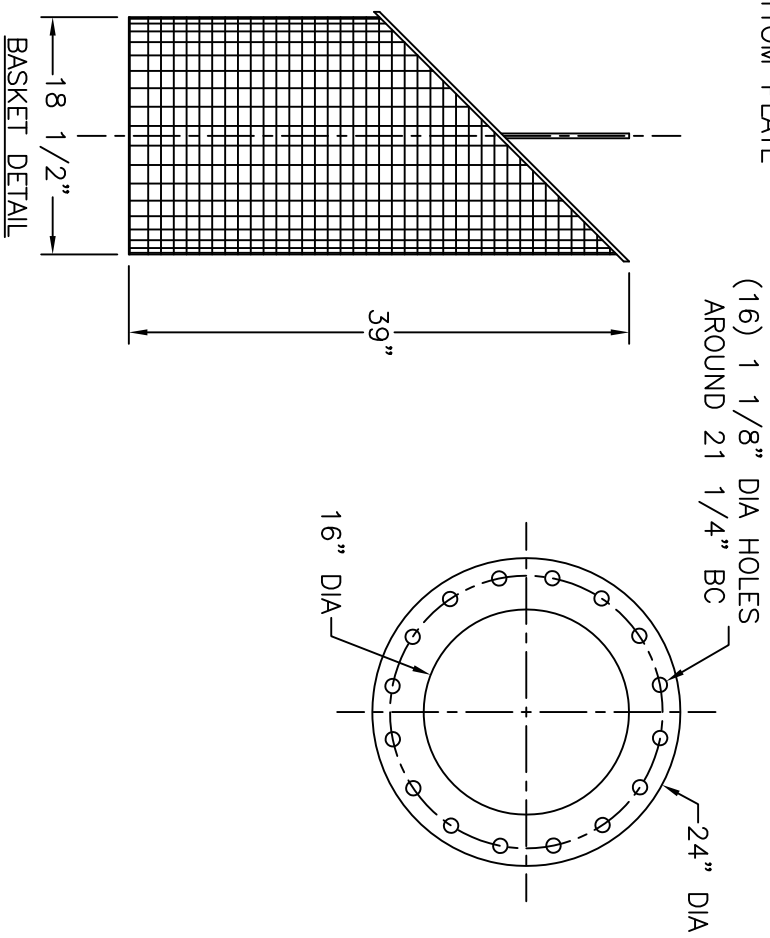
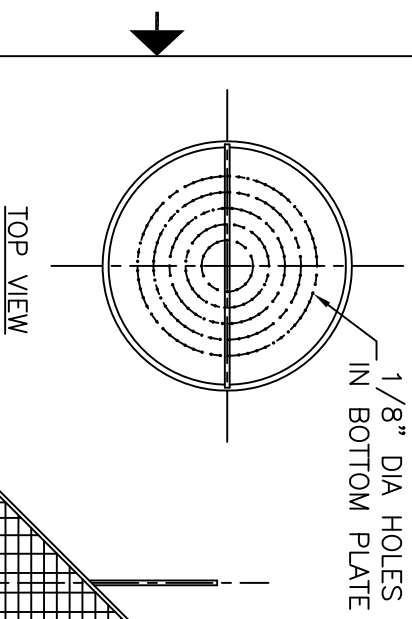
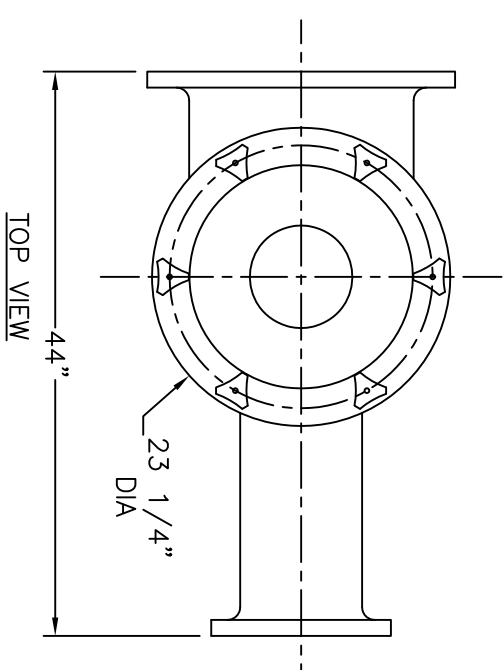

CERTIFIED FOR PRODUCTION

BY: _____ DATE: _____
MER-MADE, INC.

THIS DRAWING CONTAINS INFORMATION PROPRIETARY TO MER-MADE FILTER INCORPORATED. IT IS SUBMITTED IN CONFIDENCE AND IS TO BE USED SOLELY FOR THE PURPOSE FOR WHICH IT IS FURNISHED AND IS TO BE RETURNED UPON REQUEST. THIS DRAWING AND SPECIFICATIONS ARE NOT TO BE REPRODUCED, COPIED, EITHER WHOLLY OR IN PART, OR IN ANY MANNER WITHOUT THE WRITTEN AUTHORIZATION OF MER-MADE FILTER INCORPORATED.

TOLERANCES UNLESS OTHERWISE SPECIFIED
MACHINED DIMENSIONS:
XX ±.020 FINISH: 125/
XXX ±.010 ANGLES: ±2°
X:XXX ±.005 RADII: ±.03

FRACTIONAL DIMENSIONS:
1/X ± 1/8
REMOVE ALL BURRS AND BREAK ALL SHARP EDGES: .016 x 45°

REV	DESCRIPTION	DATE

MER-MADE PO BOX 306 DENMARK, SC 29042 P:803-793-4263 F:803-793-4265

16" X 8" T-STYLE ECCENTRIC REDUCING BASKET STRAINER

SIZE: B DWG NO. M-0183
DWN BY: SJV CHK BY: _____
SCALE: NTS DATE: 05/03/18 Sheet: 1 OF 1