

NOTES

1. STRAINER BODY: FIBERGLASS CONSTRUCTION USING ISOPHTHALIC POLYESTER RESIN AND A .100" THK. CORROSION LINER USING ONE LAYER C GLASS AND TWO LAYERS CHOPPED STRAND MAT.
2. LID: CLEAR ACRYLIC
3. TOGGLE BOLTS: STAINLESS STEEL
4. HAND KNOBS: ABS WITH BRASS INSERTS
5. O-RING: ETHYLENE PROPYLENE
6. BASKET: 316 STAINLESS STEEL WEDGE WIRE, 3/16" SQ. OPENING

-INLET AND OUTLET FLANGES SHALL HAVE 150# ANSI STANDARD DRILL PATTERNS

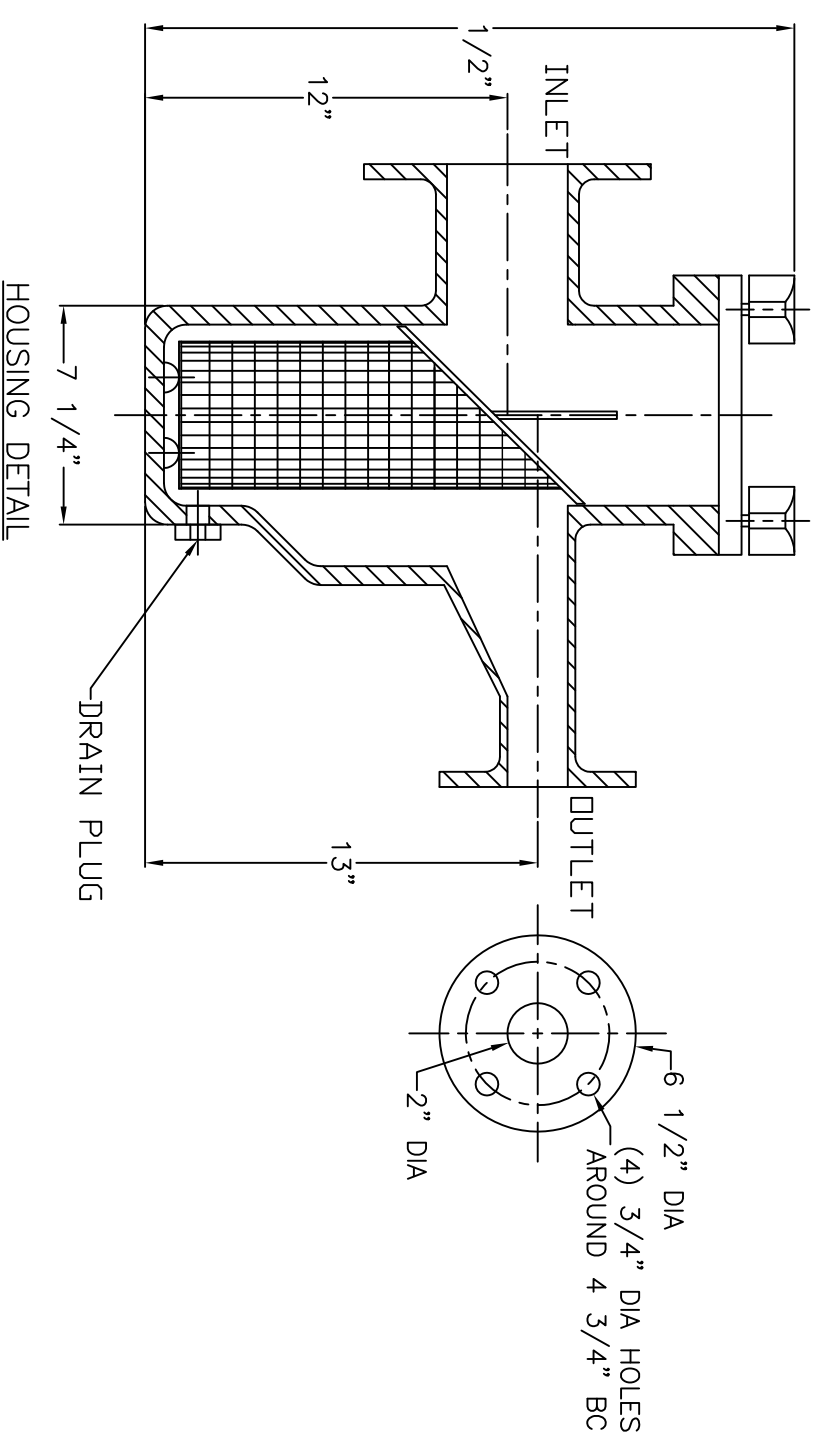
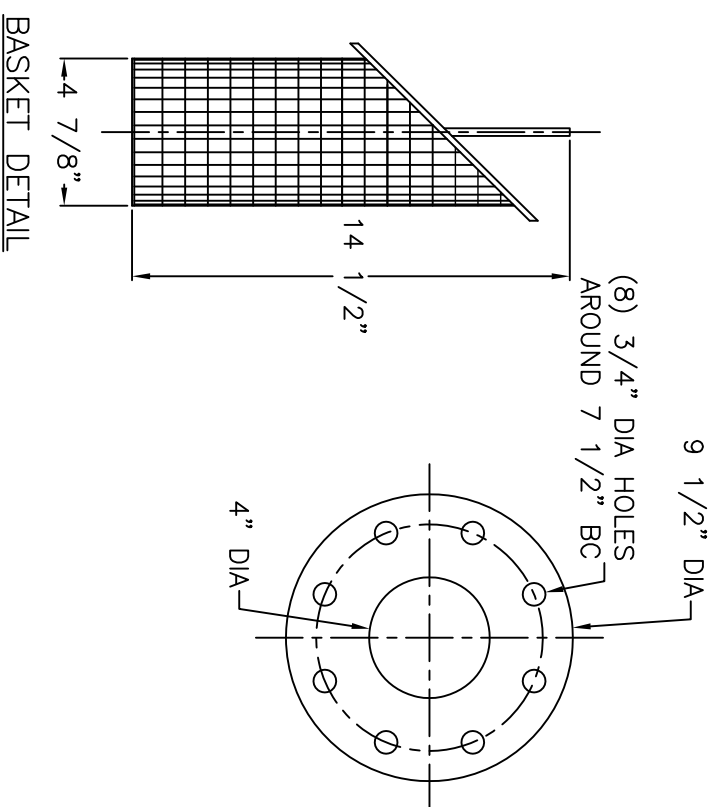
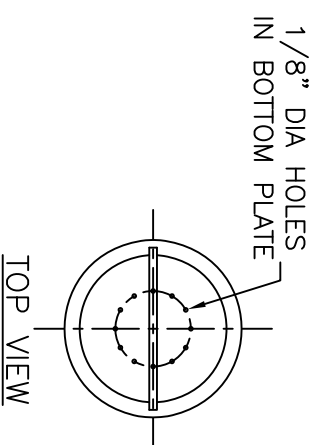
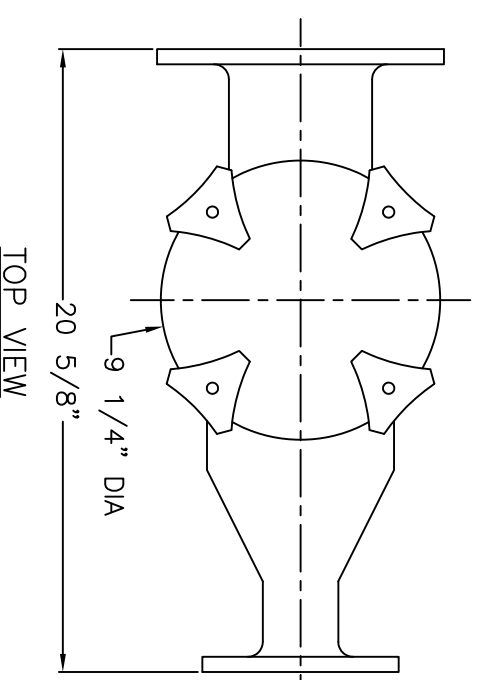

CERTIFIED FOR PRODUCTION		TOLERANCES UNLESS OTHERWISE SPECIFIED	
BY: _____ DATE: _____		MACHINED DIMENSIONS:	
MÉR-MADE, INC.		X.X ±.020	FINISH: 125/
		X.XX ±.010	ANGLES: ±.2°
		X.XXX ±.005	RADI: ±.03
		FRACTIONAL DIMENSIONS:	
		1/X ± 1/8	
THIS DRAWING CONTAINS INFORMATION PROPRIETARY TO MÉR-MADE FILTER INCORPORATED. IT IS SLIGHTLY IN CONFIDENCE AND IS TO BE RETURNED FOR THE PURPOSE FOR WHICH IT IS FURNISHED AND IS TO BE DESTROYED UPON REQUEST. THIS DRAWING IS NOT TO BE REPRODUCED, COPIED, TRANSMITTED, DISCLOSED, OR USED OTHERWISE IN WHOLE OR IN PART WITHOUT THE WRITTEN AUTHORIZATION OF MÉR-MADE FILTER INCORPORATED.		REMOVE ALL BURRS AND BREAK ALL SHARP EDGES: .016 x 45°	
REV	DESCRIPTION	DATE	SCALE: NTS
			DATE: 11/15/17
			Sheet: 1 OF 1
MÉR-MADE		PO BOX 306 DENMARK, SC 29042 P:803-793-4263 F:803-793-4265	
4" X 2" ECCENTRIC REDUCING FO SERIES STRAINER		SIZE: B	DWG NO. M-0104
		DWN BY: SJV	REV: RO
		CHK BY:	