

**NOTES**

1. STRAINER BODY: FIBERGLASS CONSTRUCTION USING ISOPHTHALIC POLYESTER RESIN AND A .100" THK. CORROSION LINER USING ONE LAYER C GLASS AND TWO LAYERS CHOPPED STRAND MAT.
  2. LID: CLEAR ACRYLIC
  3. TOGGLE BOLTS: STAINLESS STEEL
  4. HAND KNOBS: ABS WITH BRASS INSERTS
  5. O-RING: ETHYLENE PROPYLENE
  6. BASKET: 316 STAINLESS STEEL WEDGE WIRE, 3/16" SQ. OPENING
- INLET AND OUTLET FLANGES SHALL HAVE 150# ANSI STANDARD DRILL PATTERNS

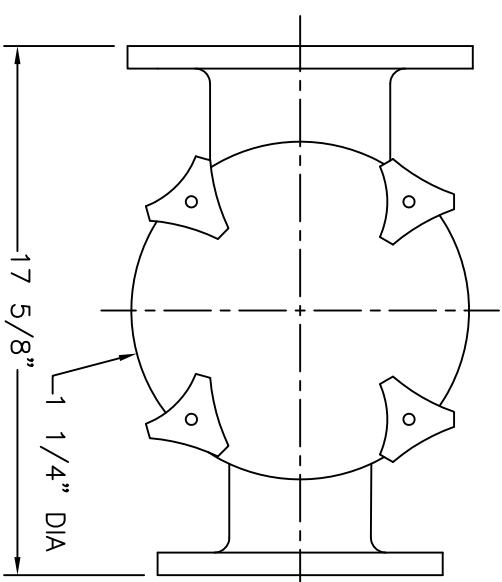

TOP VIEW

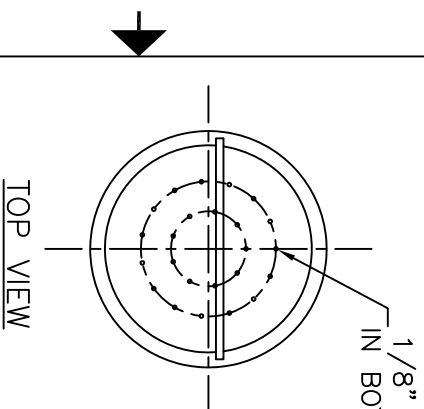

TOP VIEW

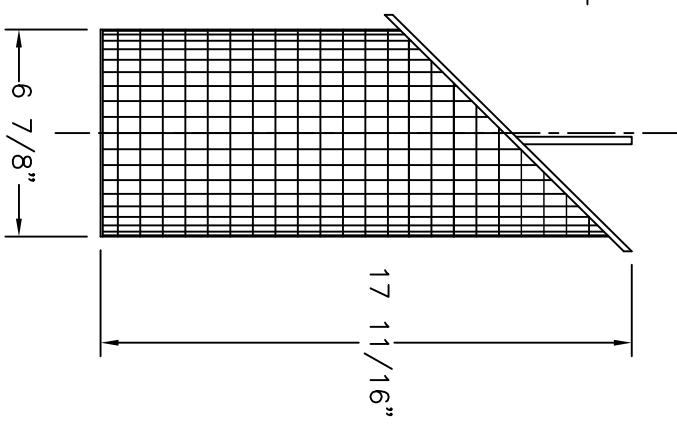

BASKET DETAIL

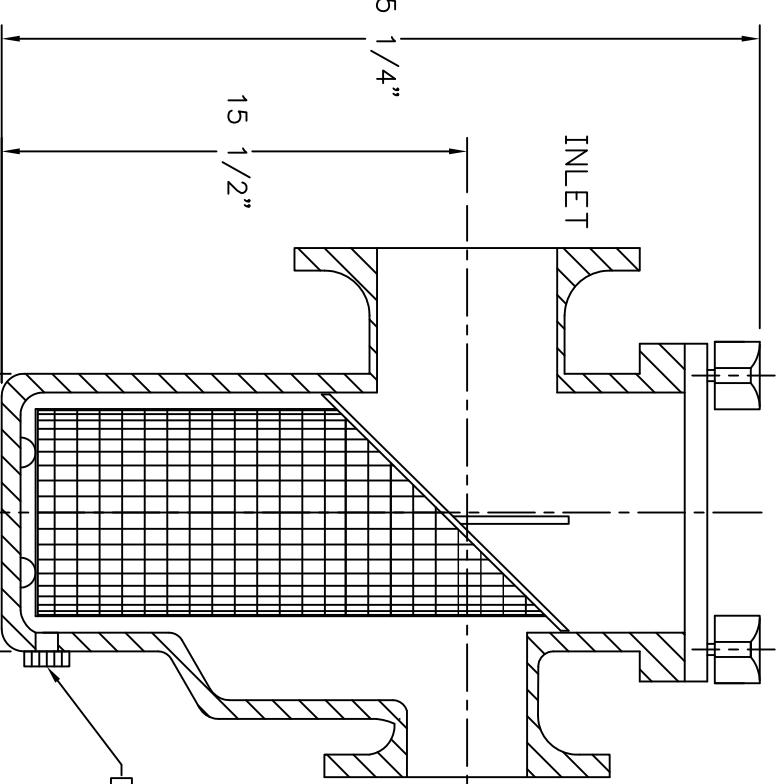
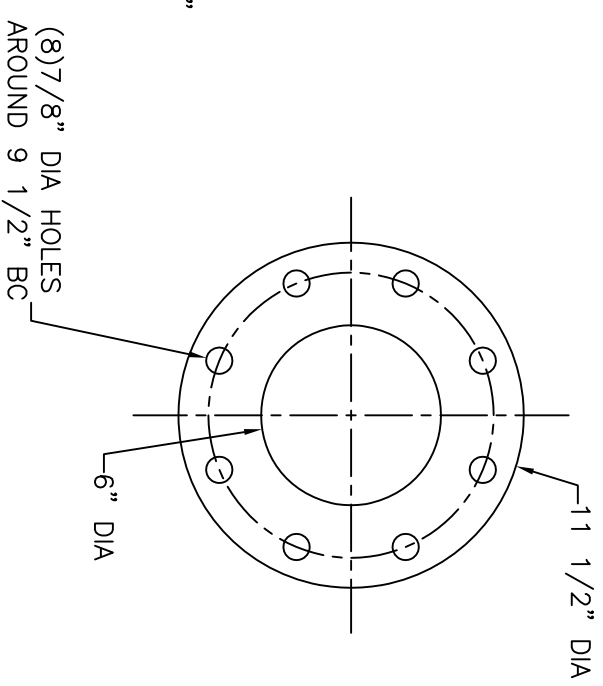

HOUSING DETAIL

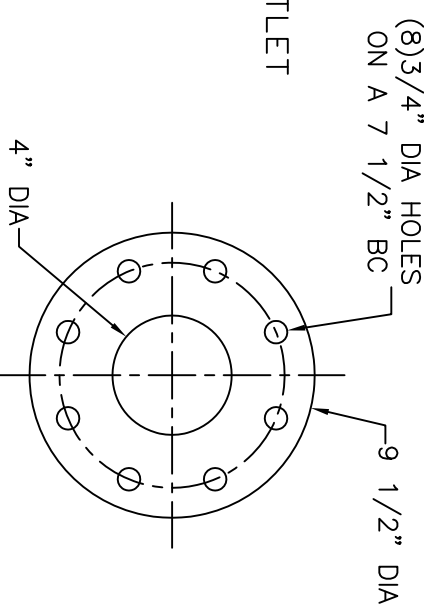

TOP VIEW

CERTIFIED FOR PRODUCTION

BY: \_\_\_\_\_ DATE: \_\_\_\_\_

MER-MADE, INC.

THIS DRAWING CONTAINS INFORMATION PROPRIETARY TO MER-MADE FILTER INCORPORATED. IT IS SLIGHTLY IN CONFIDENCE AND IS TO BE RETURNED UPON THE PURPOSE FOR WHICH IT IS FURNISHED AND IS NOT TO BE REPRODUCED, TRANSMITTED, DISCLOSED, OR USED OTHERWISE IN WHOLE OR IN PART WITHOUT THE WRITTEN AUTHORIZATION OF MER-MADE FILTER INCORPORATED.

TOLERANCES UNLESS OTHERWISE SPECIFIED

MACHINED DIMENSIONS:

X.X ±.020 FINISH: 125/  
 X.XX ±.010 ANGLES: ±.2°  
 X.XXX ±.005 RADII: ±.03

FRACTIONAL DIMENSIONS:

1/X ± 1/8

REMOVE ALL BURRS AND BREAK ALL SHARP EDGES: .016 x 45°

| REV | DESCRIPTION | DATE |
|-----|-------------|------|
|     |             |      |
|     |             |      |
|     |             |      |

**MER-MADE** PO BOX 306  
 DENMARK, SC 29042  
 P:803-793-4263 F:803-793-4265

6" X 4" STANDARD REDUCING  
 FO SERIES BASKET STRAINER

SIZE: B DWN BY: WGM DWG NO. M-0137  
 SCALE: NTS DATE: 3/23/18 Sheet: 1 OF 1