

NOTES

1. STRAINER BODY: FIBERGLASS CONSTRUCTION USING ISOPHTHALIC POLYESTER RESIN AND A .100" THK. CORROSION LINER USING ONE LAYER C GLASS AND TWO LAYERS CHOPPED STRAND MAT.
2. LID: CLEAR ACRYLIC
3. TOGGLE BOLTS: STAINLESS STEEL
4. HAND KNOBS: ABS WITH BRASS INSERTS
5. O-RING: ETHYLENE PROPYLENE
6. BASKET: 316 STAINLESS STEEL WEDGE WIRE, 3/16" SQ. OPENING

INLET AND OUTLET FLANGES SHALL HAVE 150# ANSI STANDARD DRILL PATTERNS

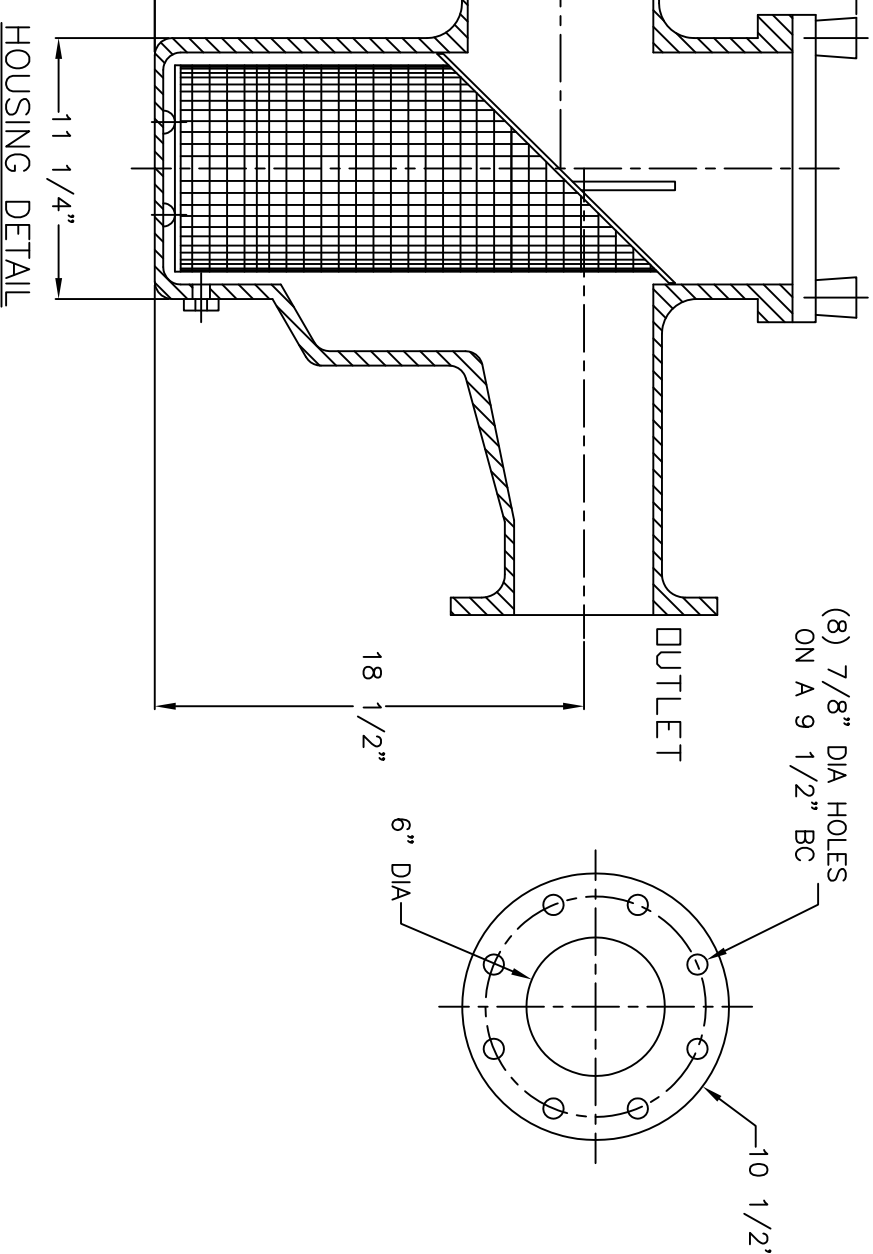
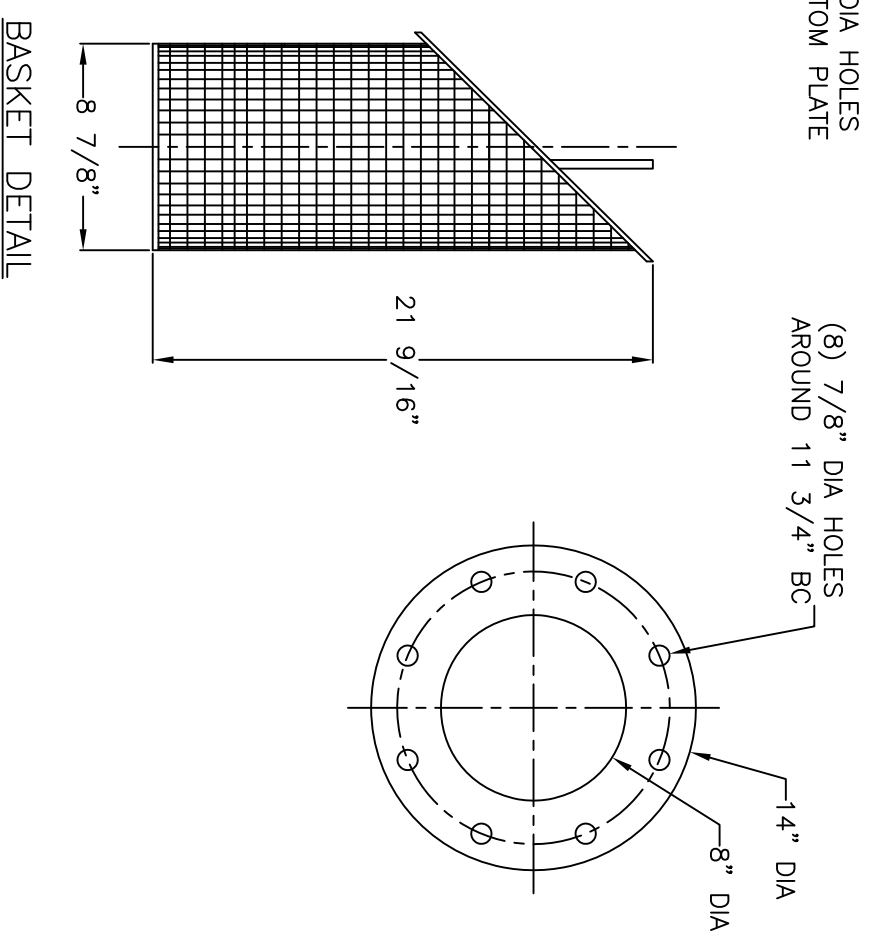
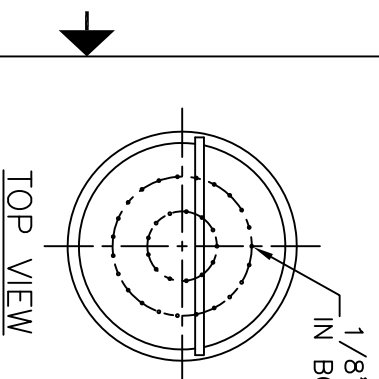
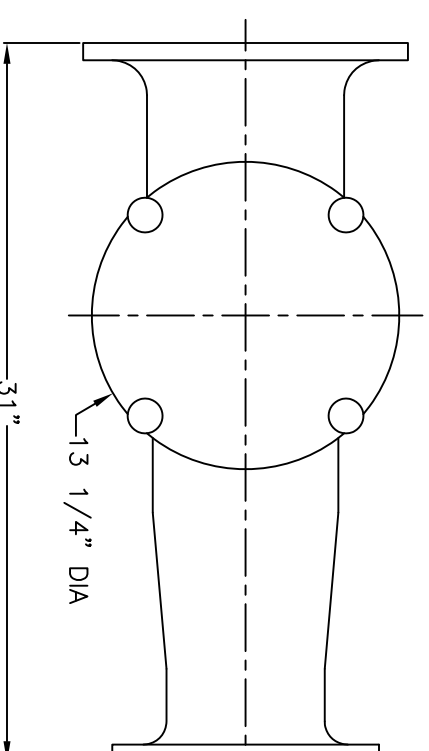

CERTIFIED FOR PRODUCTION	
BY: _____	DATE: _____
MER-MADE, INC.	

THIS DRAWING CONTAINS INFORMATION PROPRIETARY TO MER-MADE FILTER INCORPORATED. IT IS SLIGHTED IN CONFIDENCE AND IS TO BE RETURNED UPON THE PURPOSE FOR WHICH IT IS FURNISHED AND IS TO BE DESTROYED UPON REQUEST. THIS DRAWING OR USED OTHERWISE IN WHOLE OR IN PART WITHOUT THE WRITTEN AUTHORIZATION OF MER-MADE FILTER INCORPORATED.

TOLERANCES UNLESS OTHERWISE SPECIFIED		
MACHINED DIMENSIONS:		
X.X	± .020	FINISH: 125/
X.XX	± .010	ANGLES: ± 2
X.XXX	± .005	RADII: ± .03
FRACTIONAL DIMENSIONS:		
1/X	± 1/8	
REMOVE ALL BURRS AND BREAK ALL SHARP EDGES: .016 x 45°		

REV	DESCRIPTION	DATE

<b>MER-MADE</b>		PO BOX 306
DENMARK, SC 29042		
P:803-793-4263 F:803-793-4265		
8" X 6" FO SERIES ECCENTRIC		SIZE
REDUCING BASKET STRAINER		DWN BY: SUV
SCALE: NTS	DATE: 12/11/17	DWG NO. M-0119
		REV RO
		Sheet: 1 OF 1