

NOTES

1. STRAINER BODY: FIBERGLASS CONSTRUCTION USING ISOPHTHALIC POLYESTER RESIN AND A .100" CORROSION LINER USING ONE LAYER C-GLASS AND TWO LAYERS CHOPPED STRAND MAT.
2. LID: CLEAR ACRYLIC
3. TOGGLE BOLTS: STAINLESS STEEL
4. HAND KNOBS: ABS WITH BRASS INSERTS
5. O-RING: ETHYLENE PROPYLENE
6. BASKET: 316 STAINLESS STEEL WEDGE WIRE, 3/16" SQ. OPENING

INLET AND OUTLET FLANGES SHALL HAVE 150# ANSI STANDARD DRILL PATTERNS.

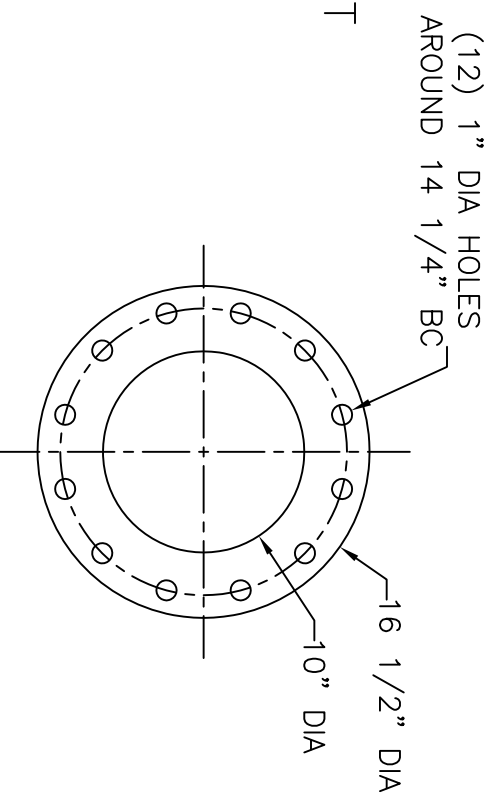
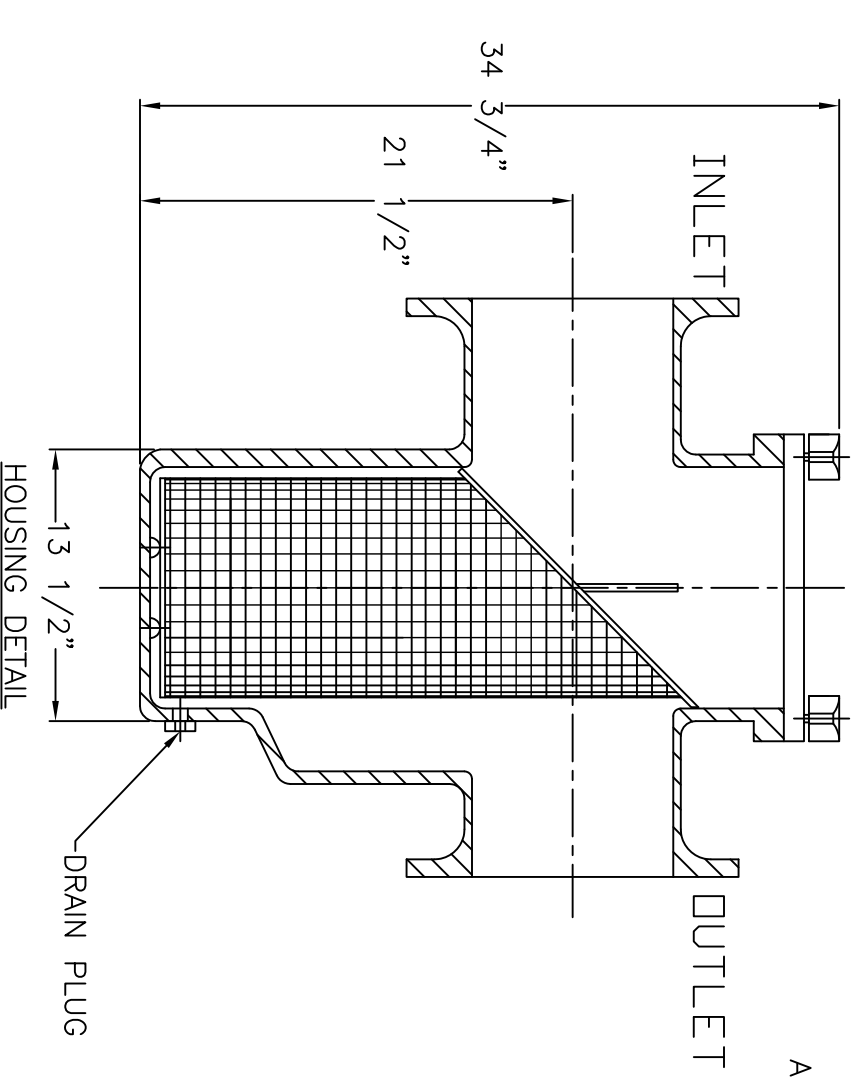
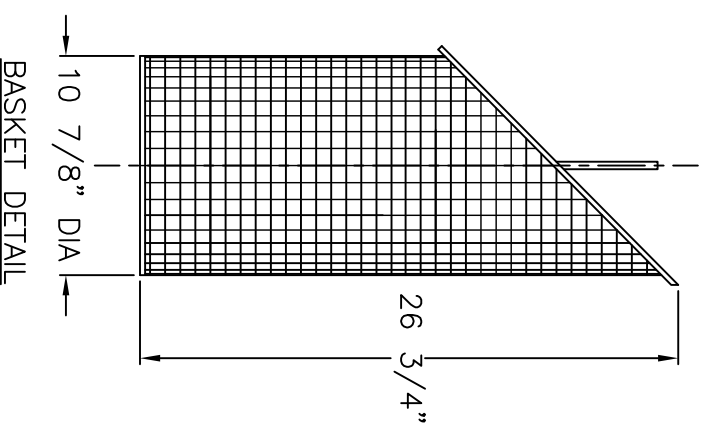
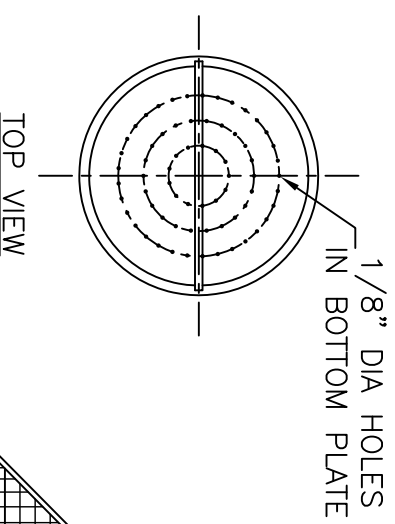
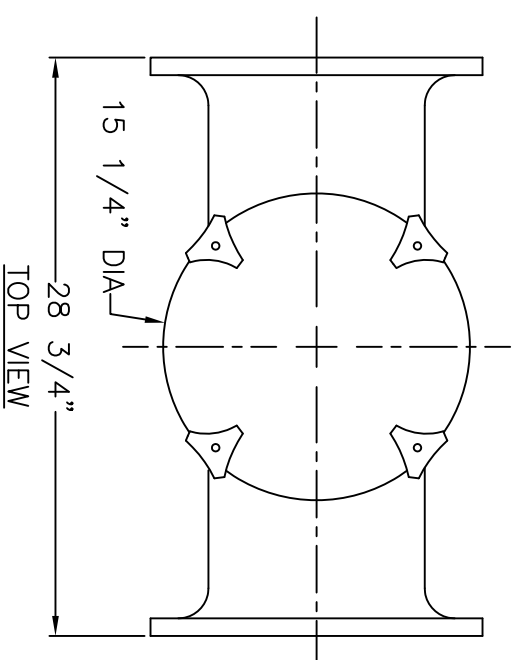

CERTIFIED FOR PRODUCTION

BY: _____ DATE: _____

LEEM FILTRATION, INC.

THIS DRAWING CONTAINS INFORMATION PROPRIETARY TO LEEM FILTRATION INCORPORATED. IT IS SLIGHTED IN CONFIDENCE AND IS TO BE RETURNED UPON THE PURPOSE FOR WHICH IT IS FURNISHED AND IS TO BE KEPT UNREPRODUCED, UNLESS DISCUSSED OR USED OTHERWISE IN WHOLE OR IN PART WITHOUT THE WRITTEN AUTHORIZATION OF LEEM FILTRATION INCORPORATED.

TOLERANCES UNLESS OTHERWISE SPECIFIED

MACHINED DIMENSIONS:

X.X ±.020 FINISH: 125/
 X.XX ±.010 ANGLES: ±.2°
 X.XXX ±.005 RADII: ±.03

FRACTIONAL DIMENSIONS:

1/X ± 1/8

REMOVE ALL BURRS AND BREAK ALL SHARP EDGES: .016 x 45°

REV	DESCRIPTION	DATE

MERSMADE PO BOX 306 DENMARK, SC 29042 P:803-793-4263 F:803-793-4332

10" FO SERIES FRP BASKET STRAINER

SIZE: B DWN BY: SUV DWG NO. FO-10X10-STR
 SCALE: NTS DATE: 10/20/17 Sheet: 1 OF 1