

- NOTES**
1. STRAINER BODY: FIBERGLASS CONSTRUCTION USING ISOPHTHALIC POLYESTER RESIN AND A .100" THK. CORROSION LINER USING ONE LAYER C GLASS AND TWO LAYERS CHOPPED STRAND MAT.
 2. LID: CLEAR ACRYLIC
 3. TOGGLE BOLTS: STAINLESS STEEL
 4. HAND KNOBS: ABS WITH BRASS INSERTS
 5. O-RING: ETHYLENE PROPYLENE
 6. BASKET: 316 STAINLESS STEEL WEDGE WIRE, 3/16" SQ. OPENING

INLET AND OUTLET FLANGES SHALL HAVE 150# ANSI STANDARD DRILL PATTERNS

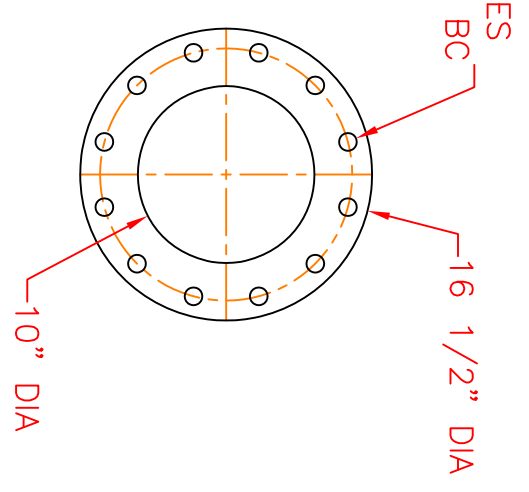
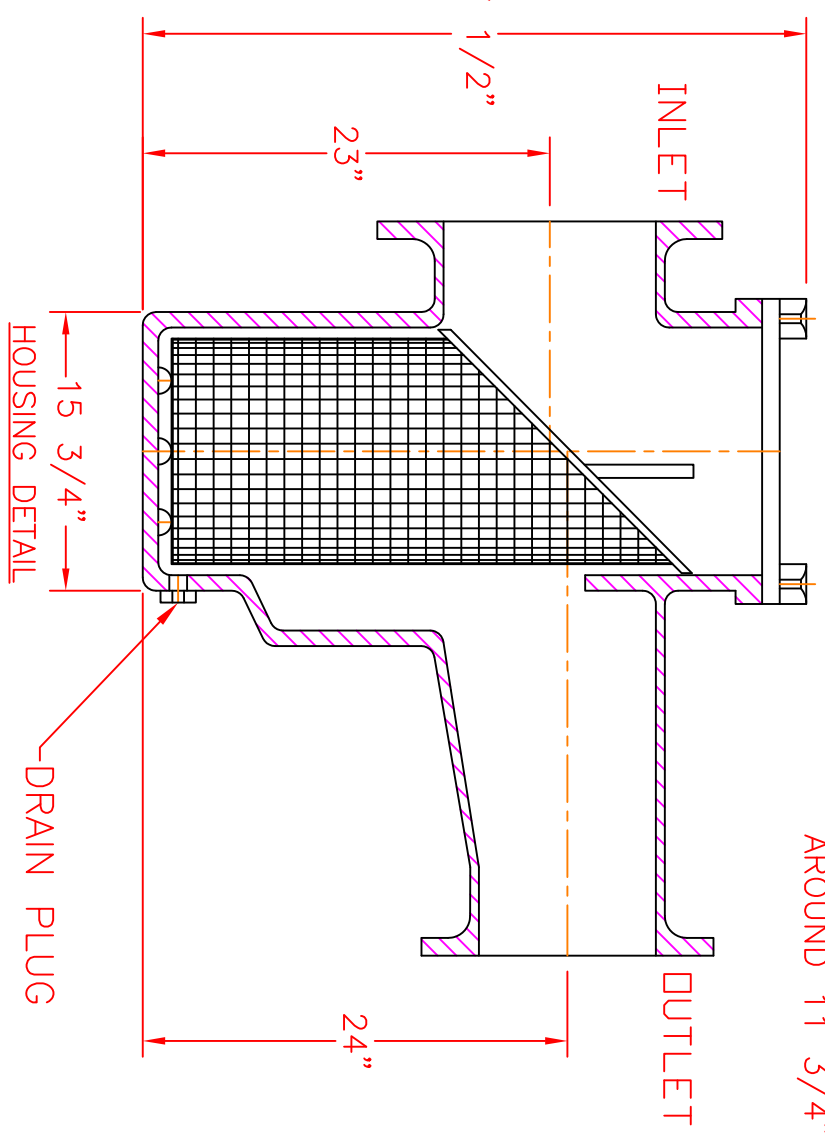
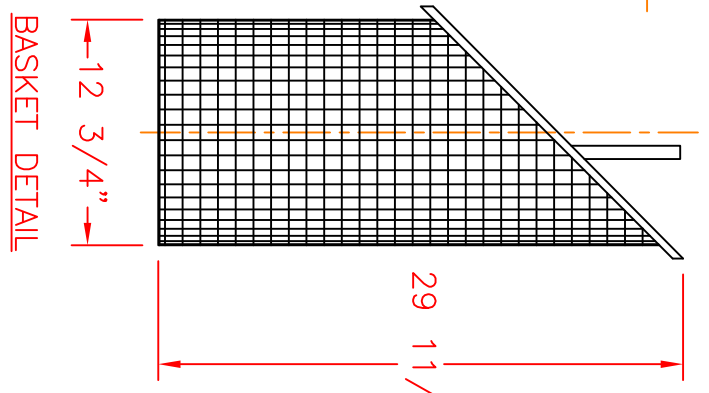
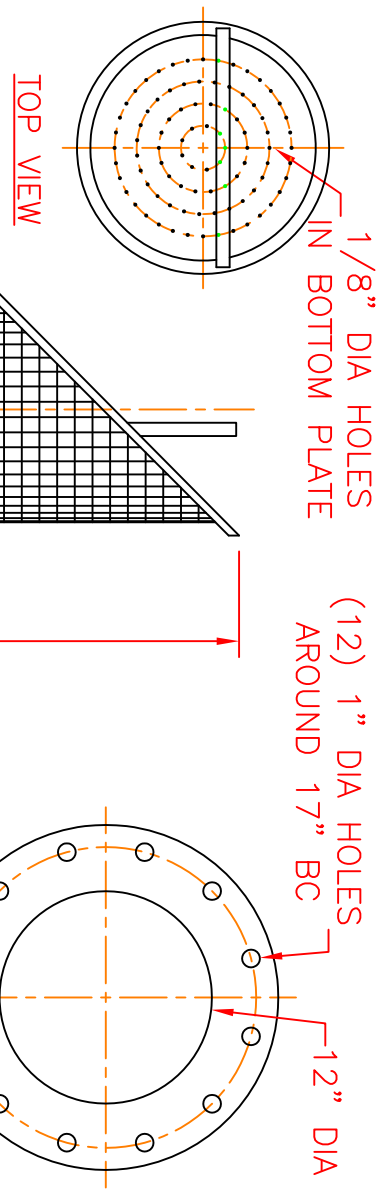
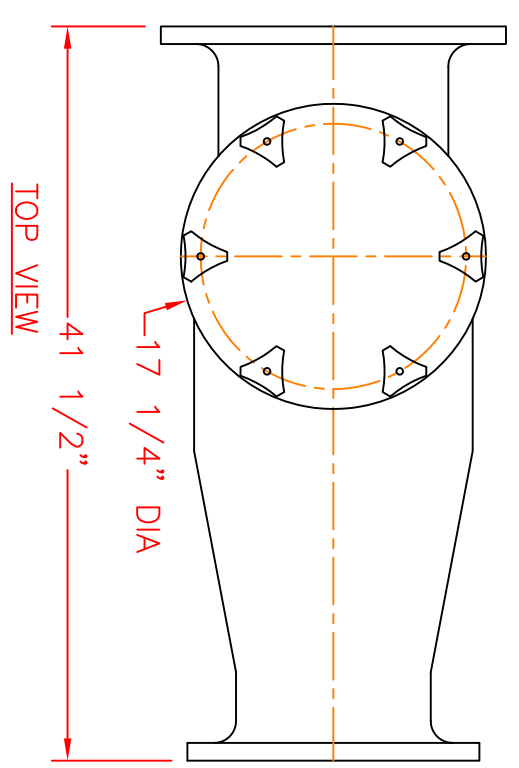

CERTIFIED FOR PRODUCTION

BY: _____ DATE: _____
MER-MADE, INC.

THIS DRAWING CONTAINS INFORMATION PROPRIETARY TO MER-MADE FILTER INCORPORATED. IT IS SLIGHTED IN CONFIDENCE AND IS TO BE USED SOLELY FOR THE PURPOSE FOR WHICH IT IS FURNISHED AND IS TO BE RETURNED UPON COMPLETION OF THE PROJECT. ANY REPRODUCTION OR USE OF THIS DRAWING WITHOUT THE WRITTEN AUTHORIZATION OF MER-MADE FILTER INCORPORATED.

TOLERANCES UNLESS OTHERWISE SPECIFIED

MACHINED DIMENSIONS:

X.X	±.020	FINISH: 125/
X.XX	±.010	ANGLES: ±2°
X.XXX	±.005	RADI: ±.03

FRACTIONAL DIMENSIONS:

1/X	± 1/8
-----	-------

REMOVE ALL BURRS AND BREAK ALL SHARP EDGES: .016 x 45°

REV	DESCRIPTION	DATE	SCALE	NTS	DATE	Sheet	OF

MER-MADE PO BOX 306 DENMARK, SC 29042 P:803-793-4263 F:803-793-4265

12" X 10" FO SERIES ECCENTRIC REDUCING BASKET STRAINER

SIZE: B DWN BY: SUV CHK BY: M-0127 DWG NO. M-0127 REV RO

SCALE: NTS DATE: 02/22/18 Sheet: 1 OF 1