

- NOTES**
1. STRAINER BODY: FIBERGLASS CONSTRUCTION USING ISOPHTHALIC POLYESTER RESIN AND A .100" CORROSION LINER USING ONE LAYER C-GLASS AND TWO LAYERS CHOPPED STRAND MAT.
  2. LID: CLEAR ACRYLIC
  3. TOGGLE BOLTS: STAINLESS STEEL
  4. HAND KNOBS: ABS WITH BRASS INSERTS
  5. O-RING: ETHYLENE PROPYLENE
  6. BASKET: 316 STAINLESS STEEL WEDGE WIRE, 3/16" SQ. OPENING

INLET AND OUTLET FLANGES SHALL HAVE 150# ANSI STANDARD DRILL PATTERNS.

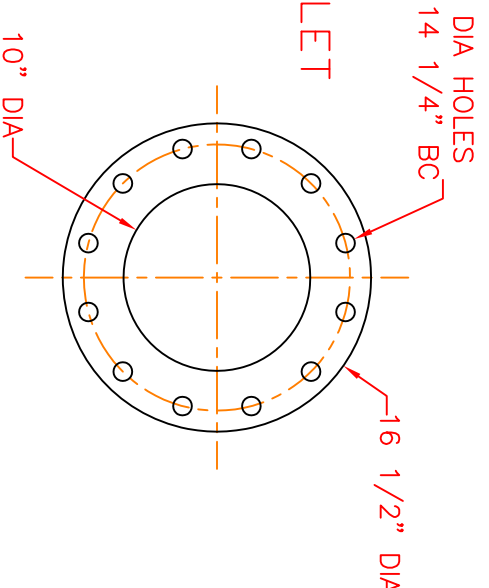
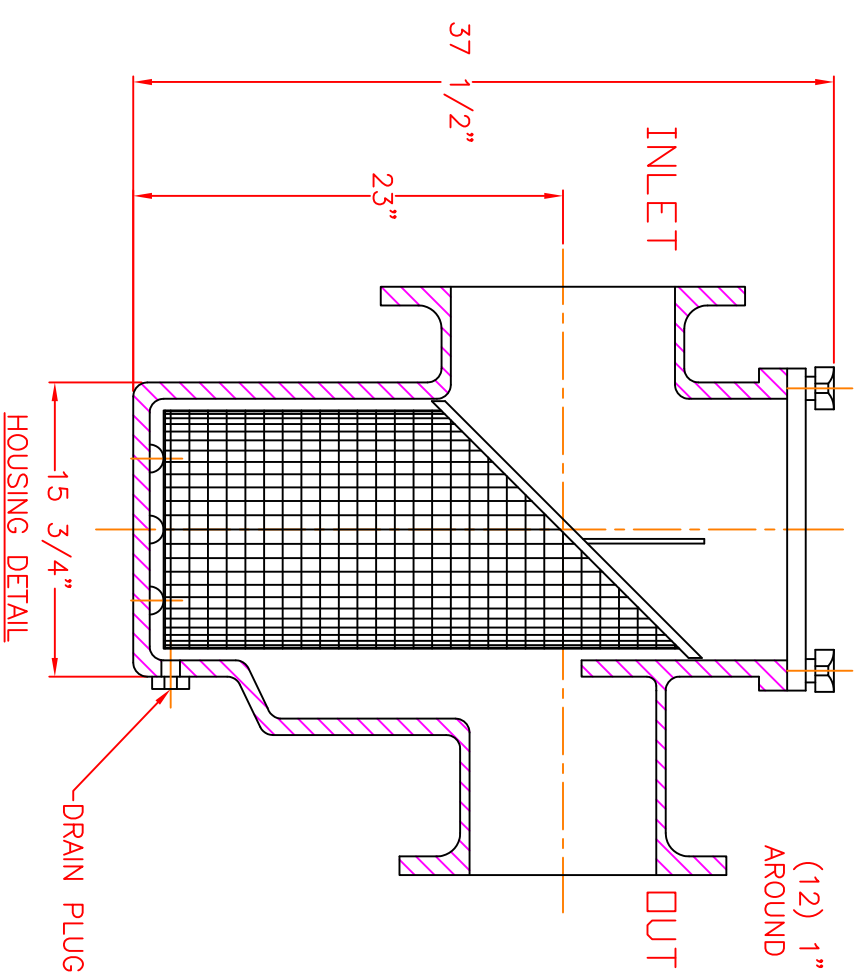
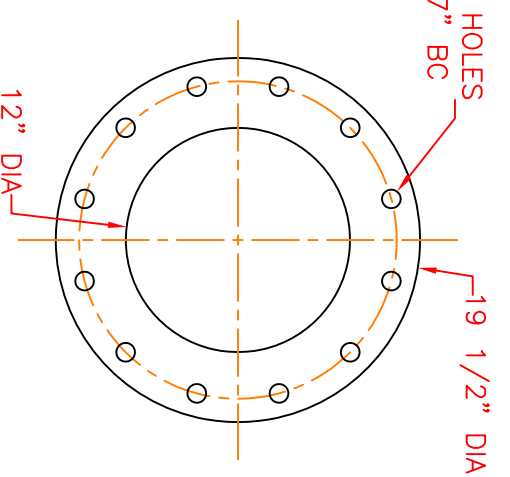
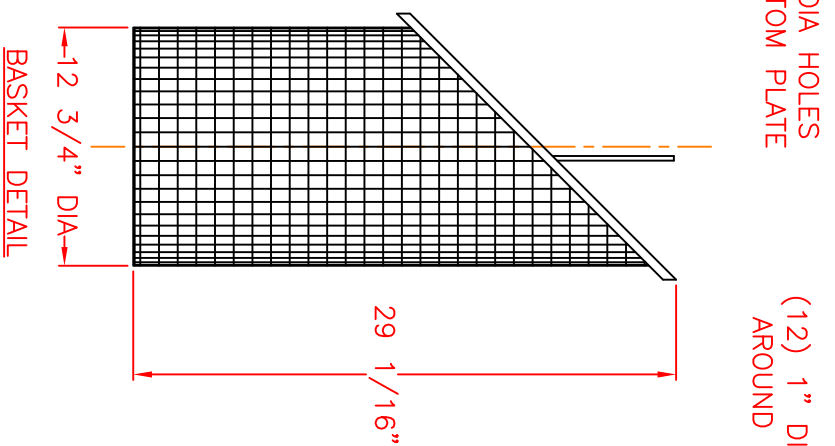
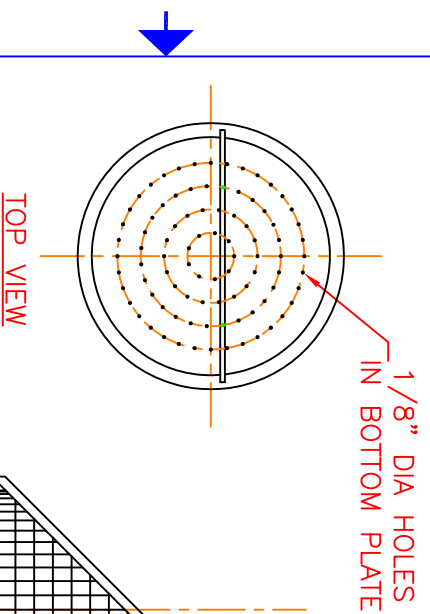
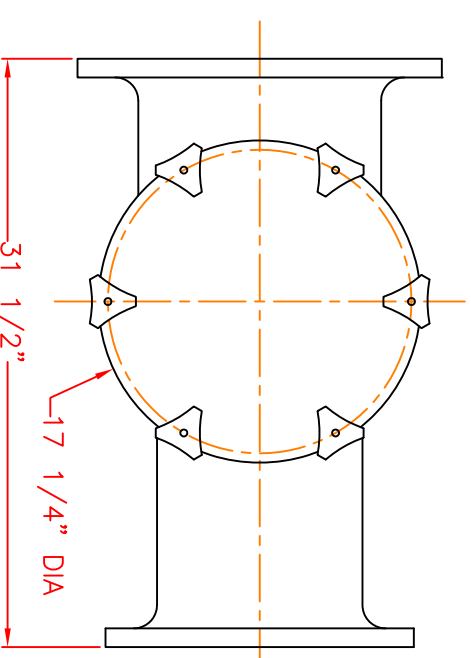

CERTIFIED FOR PRODUCTION

BY: \_\_\_\_\_ DATE: \_\_\_\_\_

LEEM FILTRATION, INC.

THIS DRAWING CONTAINS INFORMATION PROPRIETARY TO LEEM FILTRATION INCORPORATED. IT IS SLIGHTED IN CONFIDENCE AND IS TO BE RETURNED UPON REQUEST. ANY REPRODUCTION OR USE OF THIS DRAWING WITHOUT THE WRITTEN AUTHORIZATION OF LEEM FILTRATION INCORPORATED.

TOLERANCES UNLESS OTHERWISE SPECIFIED

MACHINED DIMENSIONS:

X.X ±.020 FINISH: 125/  
X.XX ±.010 ANGLES: ±2°  
X.XXX ±.005 RADII: ±.03

FRACTIONAL DIMENSIONS:

1/X ± 1/8

REMOVE ALL BURRS AND BREAK ALL SHARP EDGES: .016 x 45°

REV	DESCRIPTION	DATE

**MERSMADE**

PO BOX 306  
DENMARK, SC 29042  
P:803-793-4263 F:803-793-4332

12" X 10" REDUCING  
FO SERIES BASKET STRAINER

SIZE: B  
DWN BY: SVV  
CHK BY: \_\_\_\_\_  
DWG NO. FO-12X10-STR  
SCALE: NTS  
DATE: 03/27/18  
Sheet: 1 OF 1