

NOTES

1. STRAINER BODY: FIBERGLASS CONSTRUCTION USING ISOPHTHALIC POLYESTER RESIN AND A .100" THK. CORROSION LINER USING ONE LAYER C GLASS AND TWO LAYERS CHOPPED STRAND MAT.
2. LID: CLEAR ACRYLIC
3. TOGGLE BOLTS: STAINLESS STEEL
4. HAND KNOBS: ABS WITH BRASS INSERTS
5. O-RING: ETHYLENE PROPYLENE
6. BASKET: 316 STAINLESS STEEL WEDGE WIRE, 3/16" SQ. OPENING

-INLET AND OUTLET FLANGES SHALL HAVE 150# ANSI STANDARD DRILL PATTERNS

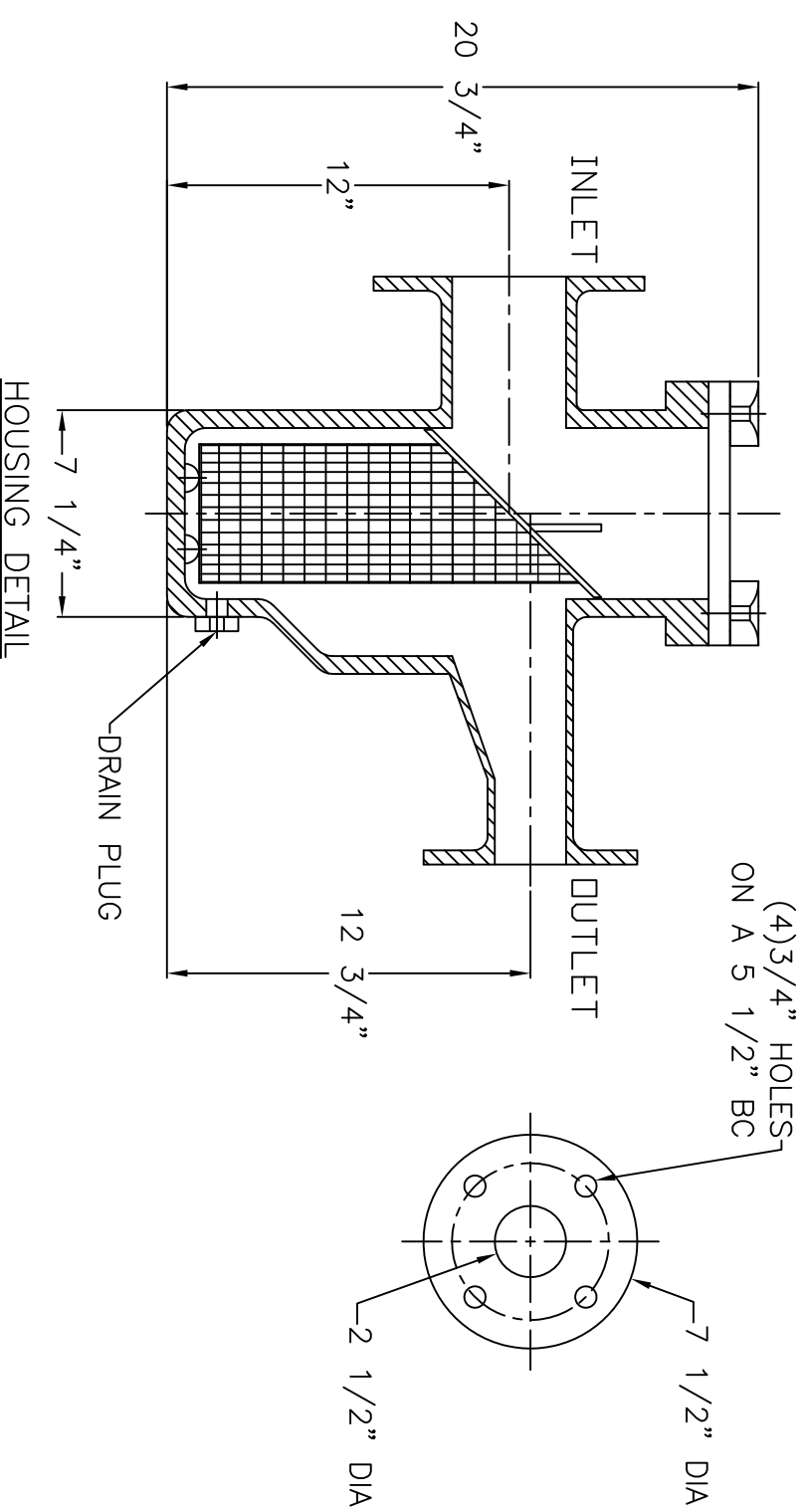
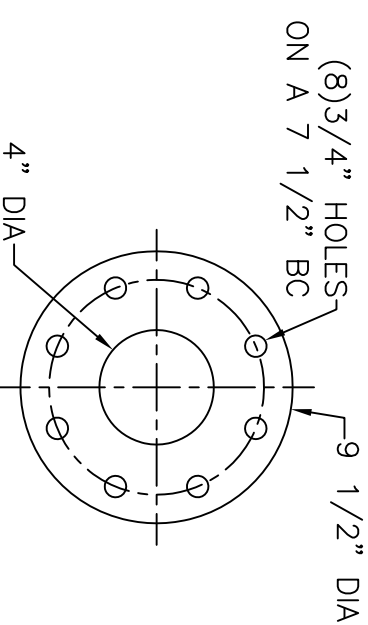
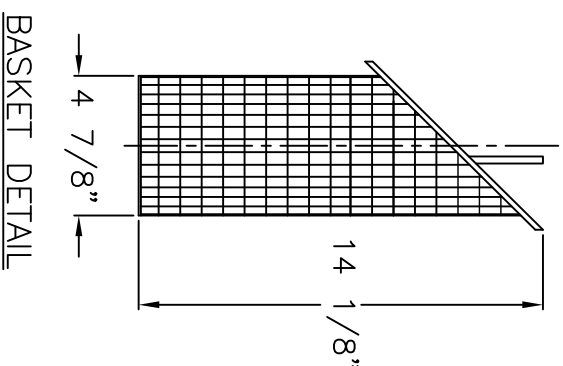
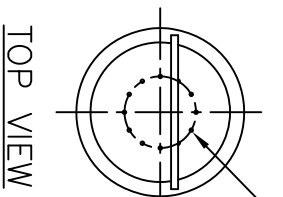
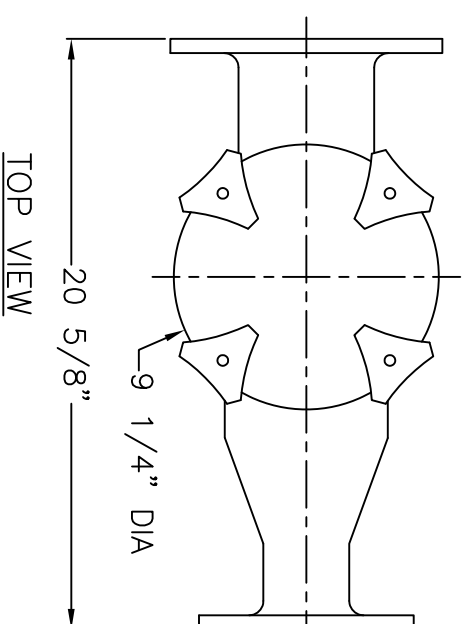

CERTIFIED FOR PRODUCTION

BY: _____ DATE: _____

MER-MADE, INC.

THIS DRAWING CONTAINS INFORMATION PROPRIETARY TO MER-MADE FILTER INCORPORATED. IT IS SLIGHTED IN CONFIDENCE AND IS TO BE RETURNED UPON REQUEST. ANY REPRODUCTION OR USE OF THIS DRAWING WITHOUT THE WRITTEN AUTHORIZATION OF MER-MADE FILTER INCORPORATED.

TOLERANCES UNLESS OTHERWISE SPECIFIED

MACHINED DIMENSIONS:

X.X ±.020 FINISH: 125/
 X.XX ±.010 ANGLES: ±.2°
 X.XXX ±.005 RADII: ±.03

FRACTIONAL DIMENSIONS:

1/X ± 1/8

REMOVE ALL BURRS AND BREAK ALL SHARP EDGES: .016 x 45°

REV	DESCRIPTION	DATE	SCALE	NTS	DATE	Sheet	OF
						1	1

MER-MADE PO BOX 306
 DENMARK, SC 29042
 P:803-793-4263 F:803-793-4265

4" X 2 1/2" FO SERIES ECCENTRIC
 REDUCING BASKET STRAINER

SIZE: B
 DWN BY: SVV
 CHK BY: _____
 DWG NO. M-0114
 REV RO