

NOTES

1. STRAINER BODY: FIBERGLASS CONSTRUCTION USING ISOPHTHALIC POLYESTER RESIN AND A .100" THK. CORROSION LINER USING ONE LAYER C GLASS AND TWO LAYERS CHOPPED STRAND MAT.
2. LID: CLEAR ACRYLIC
3. TOGGLE BOLTS: STAINLESS STEEL
4. HAND KNOBS: FRP WITH STAINLESS STEEL INSERTS
5. O-RING: ETHYLENE PROPYLENE
6. BASKET: 316 STAINLESS STEEL WEDGE WIRE, 3/16" SQ. OPENING

INLET AND OUTLET FLANGES SHALL HAVE 150# ANSI STANDARD DRILL PATTERNS

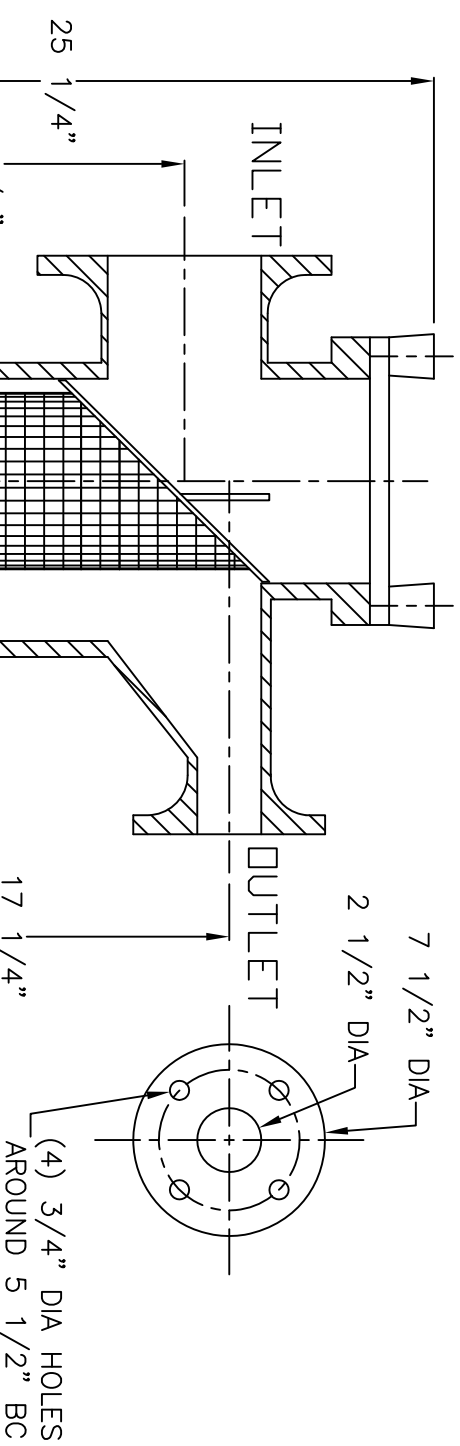
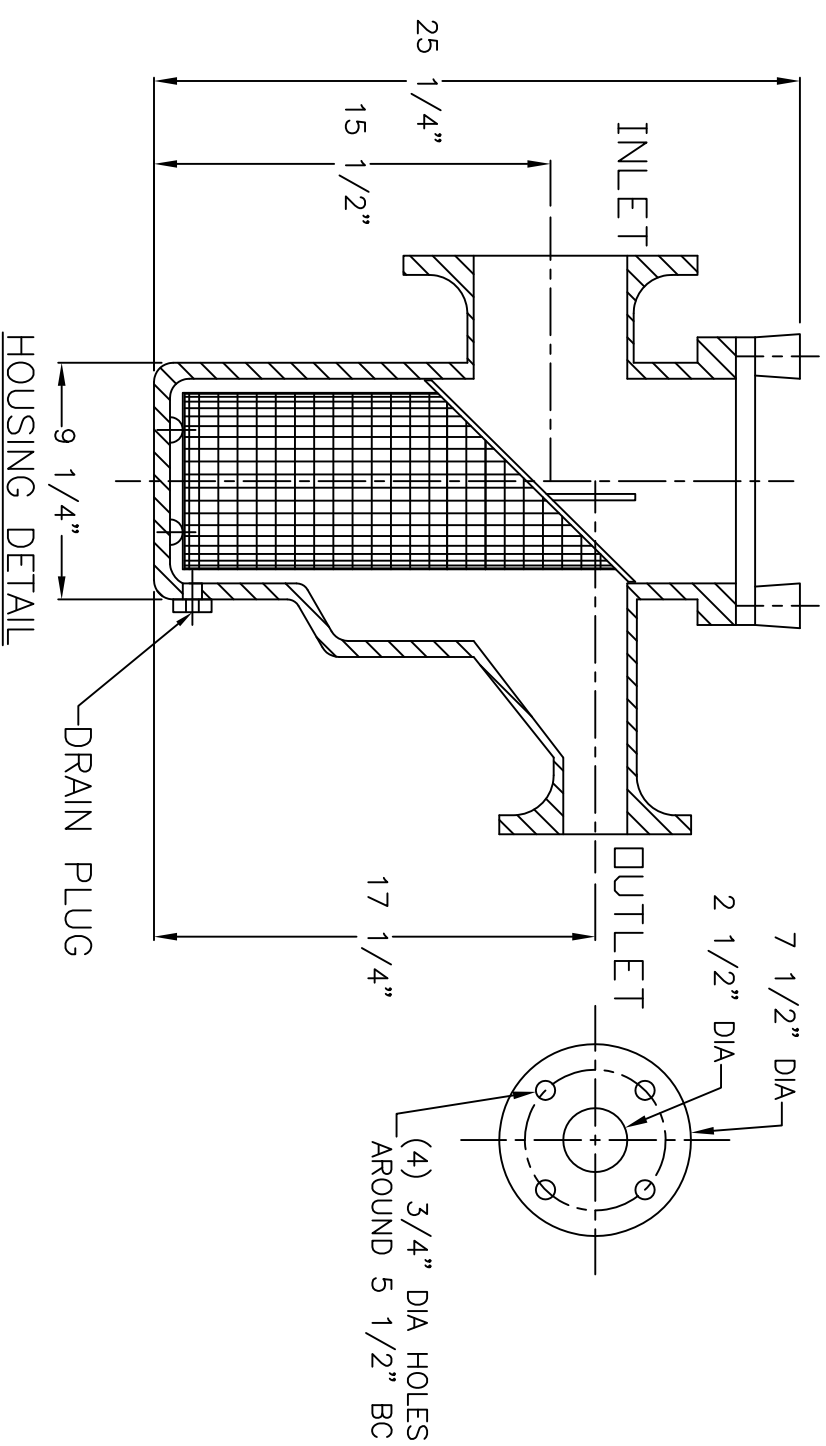
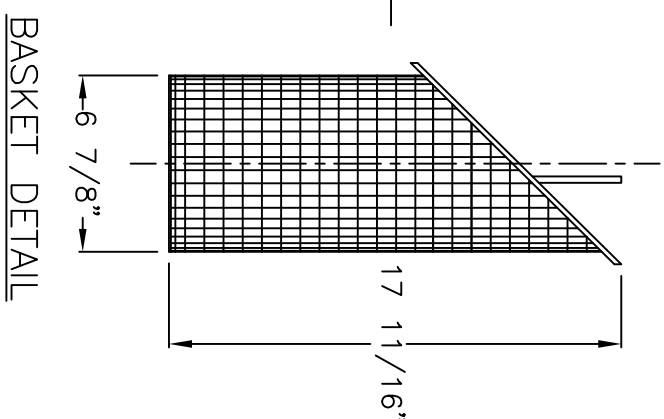
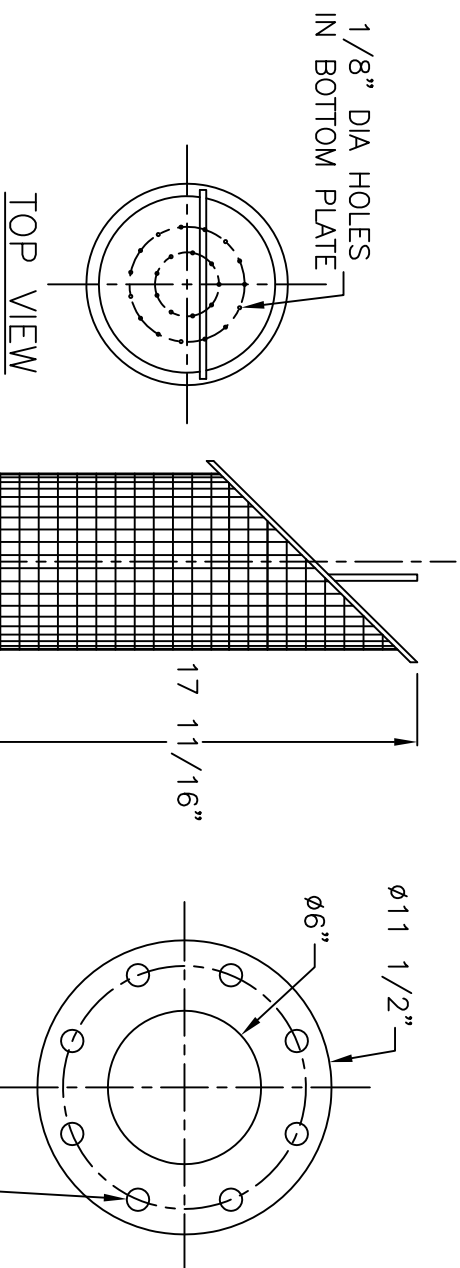
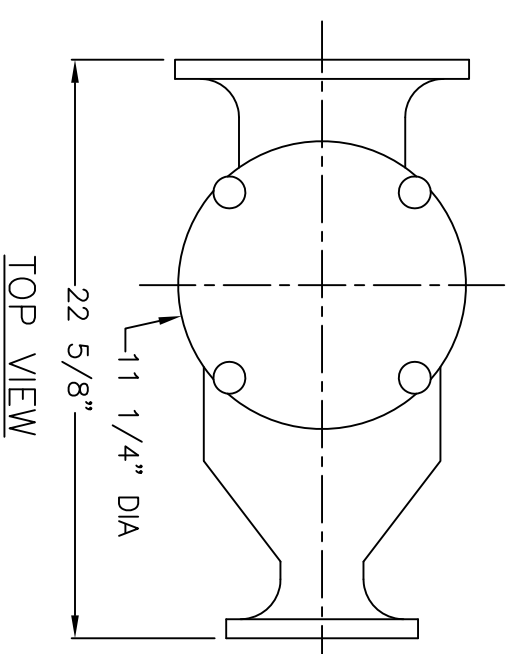

CERTIFIED FOR PRODUCTION		TOLERANCES UNLESS OTHERWISE SPECIFIED									
		MACHINED DIMENSIONS:		FINISH: 125/							
BY: _____ DATE: _____		X.X ±.020		X.XX ±.010		X.XXX ±.005		ANGLES: ±.2°		RADI: ±.03	
MÉR-MADE, INC.		FRACTIONAL DIMENSIONS:		1/X ± 1/8							
THIS DRAWING CONTAINS INFORMATION PROPRIETARY TO MÉR-MADE FILTER INCORPORATED. IT IS SLIGHTLY IN CONFIDENCE AND IS TO BE RETURNED UPON THE PURPOSE FOR WHICH IT IS FURNISHED AND IS TO BE USED SOLELY FOR THE TRANSMITTED DISCUSS OR USED OTHERWISE IN WHOLE OR IN PART WITHOUT THE WRITTEN AUTHORIZATION OF MÉR-MADE FILTER INCORPORATED.		REMOVE ALL BURRS AND BREAK ALL SHARP EDGES: .016 x 45°		REV		DESCRIPTION		DATE		SCALE: NTS	
MÉR-MADE		PO BOX 306 DENMARK, SC 29042 P:803-793-4263 F:803-793-4265		6" X 2 1/2" ECCENTRIC REDUCING		FO SERIES STRAINER		DATE: 11/16/17		Sheet: 1 OF 1	
				SIZE: B		DWN BY: SUV		CHK BY:		DWG NO. M-0107	