

**NOTES**

1. STRAINER BODY: FIBERGLASS CONSTRUCTION USING ISOPHTHALIC POLYESTER RESIN AND A .100" THK. CORROSION LINER USING ONE LAYER C GLASS AND TWO LAYERS CHOPPED STRAND MAT.
  2. LID: CLEAR ACRYLIC
  3. TOGGLE BOLTS: STAINLESS STEEL
  4. HAND KNOBS: FRP WITH STAINLESS STEEL INSERTS
  5. O-RING: ETHYLENE PROPYLENE
  6. BASKET: 316 STAINLESS STEEL WEDGE WIRE, 3/16" SQ. OPENING
- INLET AND OUTLET FLANGES SHALL HAVE 150# ANSI STANDARD DRILL PATTERNS

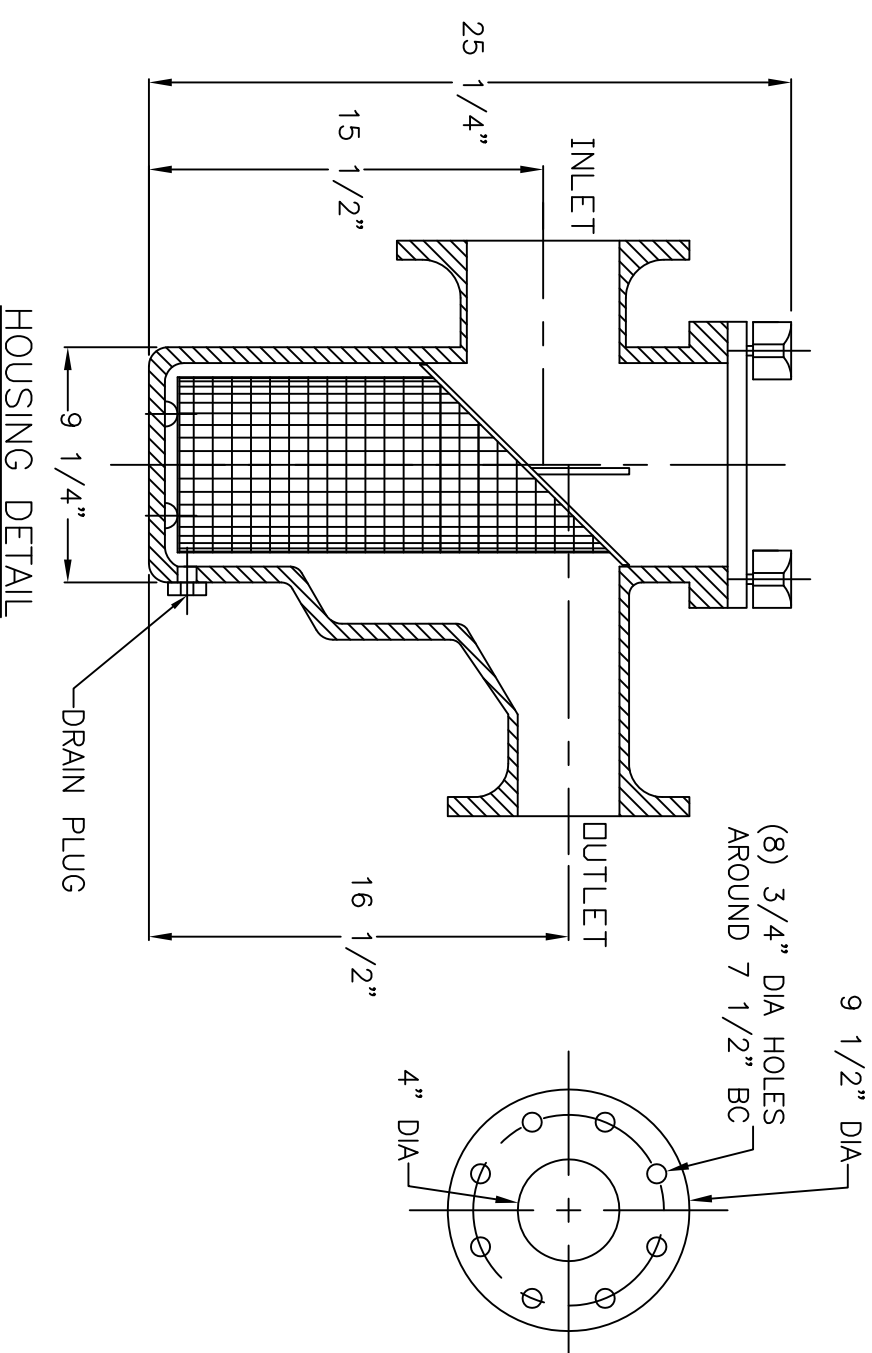
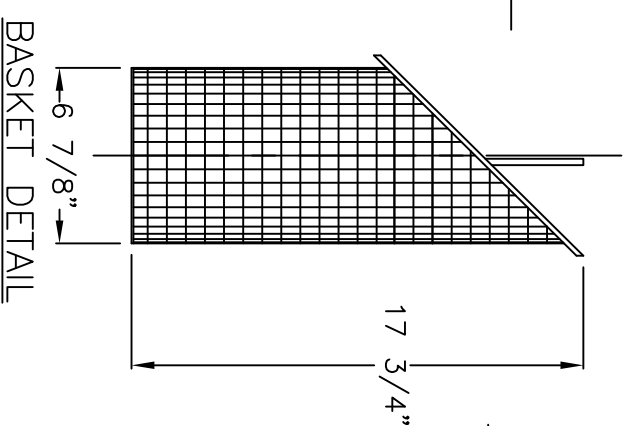
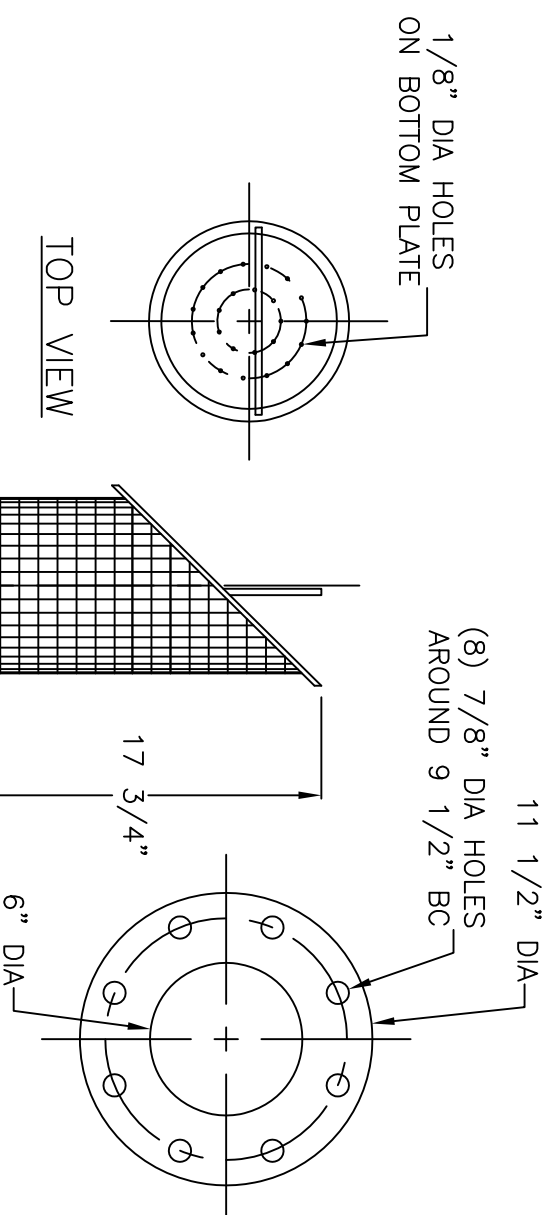
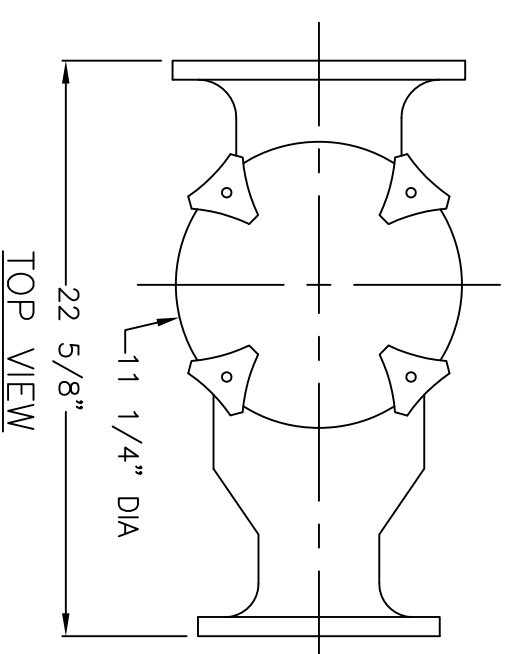

CERTIFIED FOR PRODUCTION

BY: \_\_\_\_\_ DATE: \_\_\_\_\_  
MER-MADE, INC.

THIS DRAWING CONTAINS INFORMATION PROPRIETARY TO MER-MADE FILTER INCORPORATED. IT IS SLANTED IN CONFIDENCE AND IS TO BE RETURNED UPON THE PURPOSE FOR WHICH IT IS FURNISHED AND IS TO BE DESTROYED UPON THE TRANSMITTAL DISCUSSED OR USED OTHERWISE IN WHOLE OR IN PART WITHOUT THE WRITTEN AUTHORIZATION OF MER-MADE FILTER INCORPORATED.

TOLERANCES UNLESS OTHERWISE SPECIFIED

MACHINED DIMENSIONS:

X.X	±.020	FINISH:	125/
X.XX	±.010	ANGLES:	±.2°
X.XXX	±.005	RADI:	±.03

FRACTIONAL DIMENSIONS:

1/X ± 1/8

REMOVE ALL BURRS AND BREAK ALL SHARP EDGES: .016 x 45°

REV	DESCRIPTION	DATE	SCALE:	NTS	DATE:	11/17/17	Sheet:	1	OF	1	REV
											RO

**MER-MADE**  
PO BOX 306  
DENMARK, SC 29042  
P:803-793-4263 F:803-793-4265

6" X 4" ECCENTRIC REDUCING  
FO SERIES STRAINER

SIZE: B  
DWN BY: SUV  
CHK BY: \_\_\_\_\_  
DWG NO. M-0110