

NOTES

1. STRAINER BODY: FIBERGLASS CONSTRUCTION USING ISOPHTHALIC POLYESTER RESIN, ASHLAND AROPOL 7341T-15 AND A .100" THK. CORROSION LINER USING ONE LAYER C GLASS AND TWO LAYERS CHOPPED STRAND MAT.
2. LID: CLEAR ACRYLIC
3. TOGGLE BOLTS: STAINLESS STEEL
4. HAND KNOBS: ABS WITH STAINLESS STEEL INSERTS
5. O-RING: ETHYLENE PROPYLENE
6. BASKET: 316 STAINLESS STEEL WEDGE WIRE, 3/16" SQ. OPENING

-INLET AND OUTLET FLANGES SHALL HAVE 150# ANSI STANDARD DRILL PATTERNS

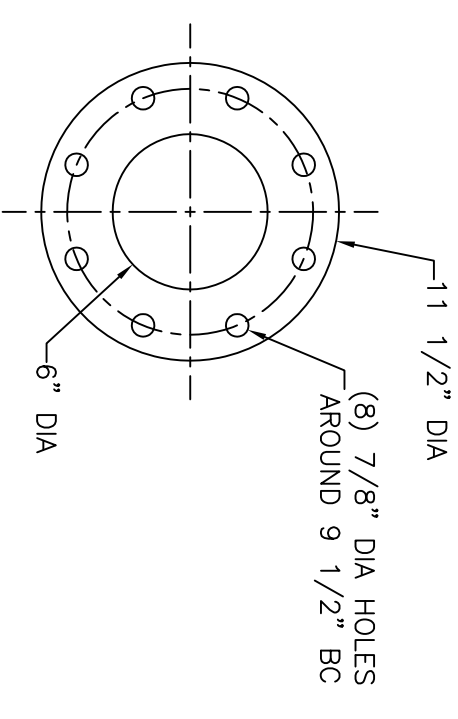
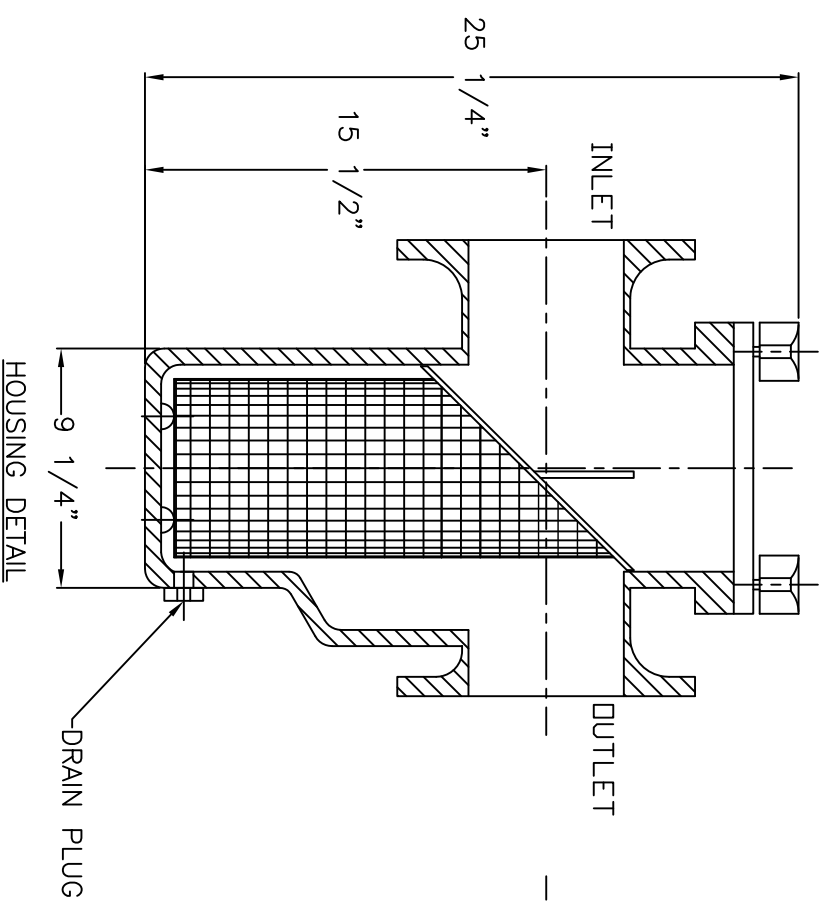
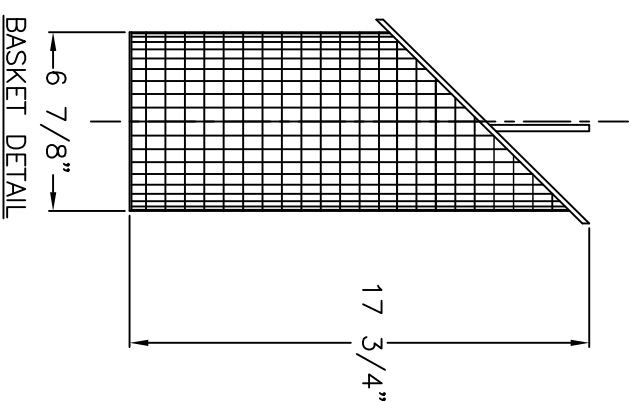
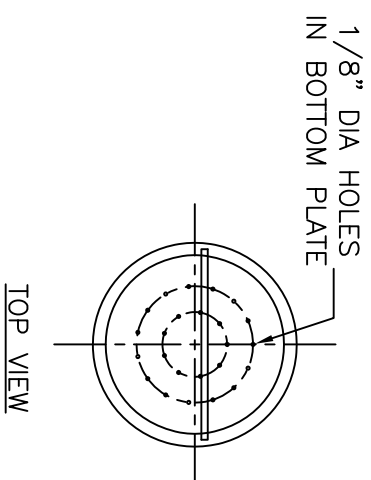
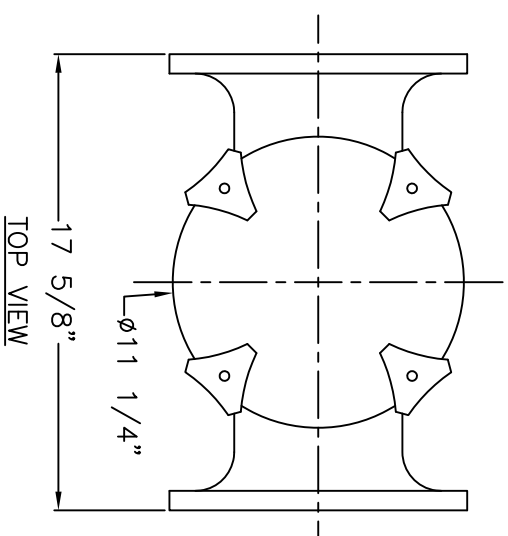

CERTIFIED FOR PRODUCTION

BY: _____ DATE: _____

MER-MADE, INC.

THIS DRAWING CONTAINS INFORMATION PROPRIETARY TO MER-MADE FILTER INCORPORATED. IT IS SLIGHTED IN CONFIDENCE AND IS TO BE USED SOLELY FOR THE PURPOSE FOR WHICH IT IS FURNISHED AND IS TO BE RETURNED UPON COMPLETION OF THE WORK FOR WHICH IT WAS FURNISHED. NO PART OF THIS DRAWING IS TO BE REPRODUCED, COPIED, TRANSMITTED, DISCLOSED OR USED OTHERWISE IN WHOLE OR IN PART WITHOUT THE WRITTEN AUTHORIZATION OF MER-MADE FILTER INCORPORATED.

TOLERANCES UNLESS OTHERWISE SPECIFIED

MACHINED DIMENSIONS:

X.X ±.020 FINISH: 125/
X.XX ±.010 ANGLES: ±Z
X.XXX ±.005 RADII: ±.03

FRACTIONAL DIMENSIONS:

1/X ± 1/8

REMOVE ALL BURRS AND BREAK ALL SHARP EDGES: .016 x 45°

REV	DESCRIPTION	DATE

MER-MADE

PO BOX 306
DENMARK, SC 29042
P:803-793-4263 F:803-793-4265

6" FO SERIES STRAINER

SIZE: B
DWN BY: SUV
CHK BY: _____
DWG NO. M-0095

SCALE: NTS
DATE: 11/14/17
Sheet: 1 OF 1
REV R0