

**NOTES**

1. STRAINER BODY: FIBERGLASS CONSTRUCTION USING ISOPHTHALIC POLYESTER RESIN AND A .100" THK. CORROSION LINER USING ONE LAYER C GLASS AND TWO LAYERS CHOPPED STRAND MAT.
2. LID: CLEAR ACRYLIC
3. TOGGLE BOLTS: STAINLESS STEEL
4. HAND KNOBS: ABS WITH BRASS INSERTS
5. O-RING: ETHYLENE PROPYLENE
6. BASKET: 316 STAINLESS STEEL WEDGE WIRE, 3/16" SQ. OPENING

INLET AND OUTLET FLANGES SHALL HAVE 150# ANSI STANDARD DRILL PATTERNS

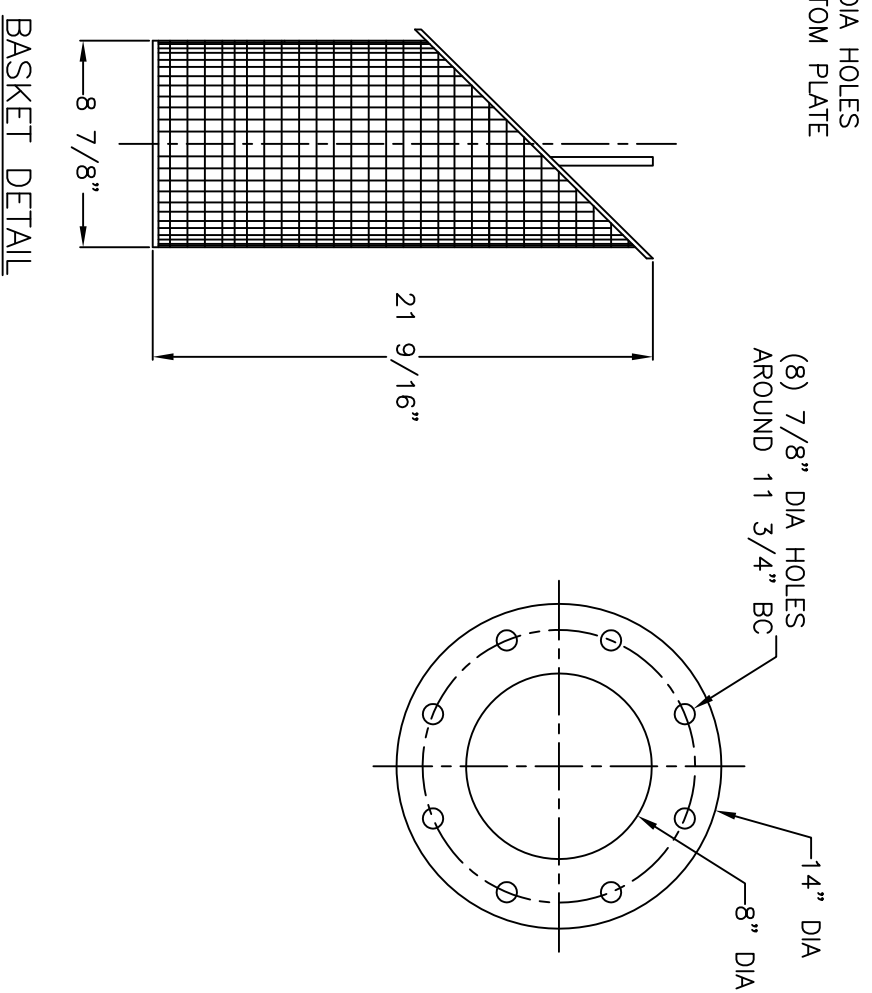
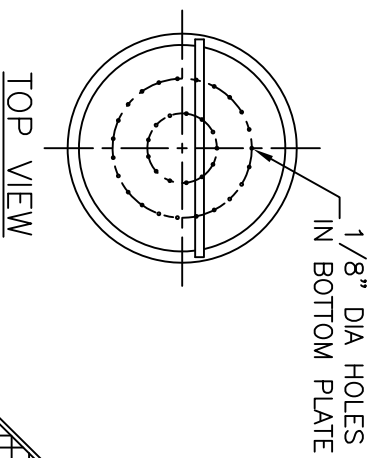
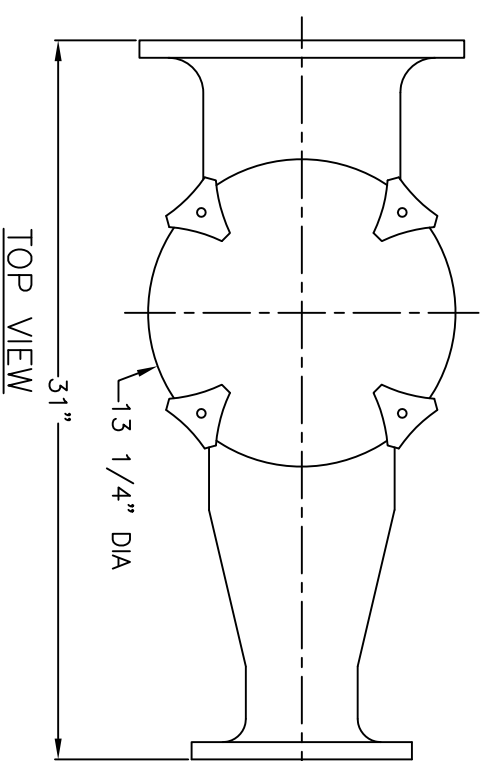

**HOUSING DETAIL**

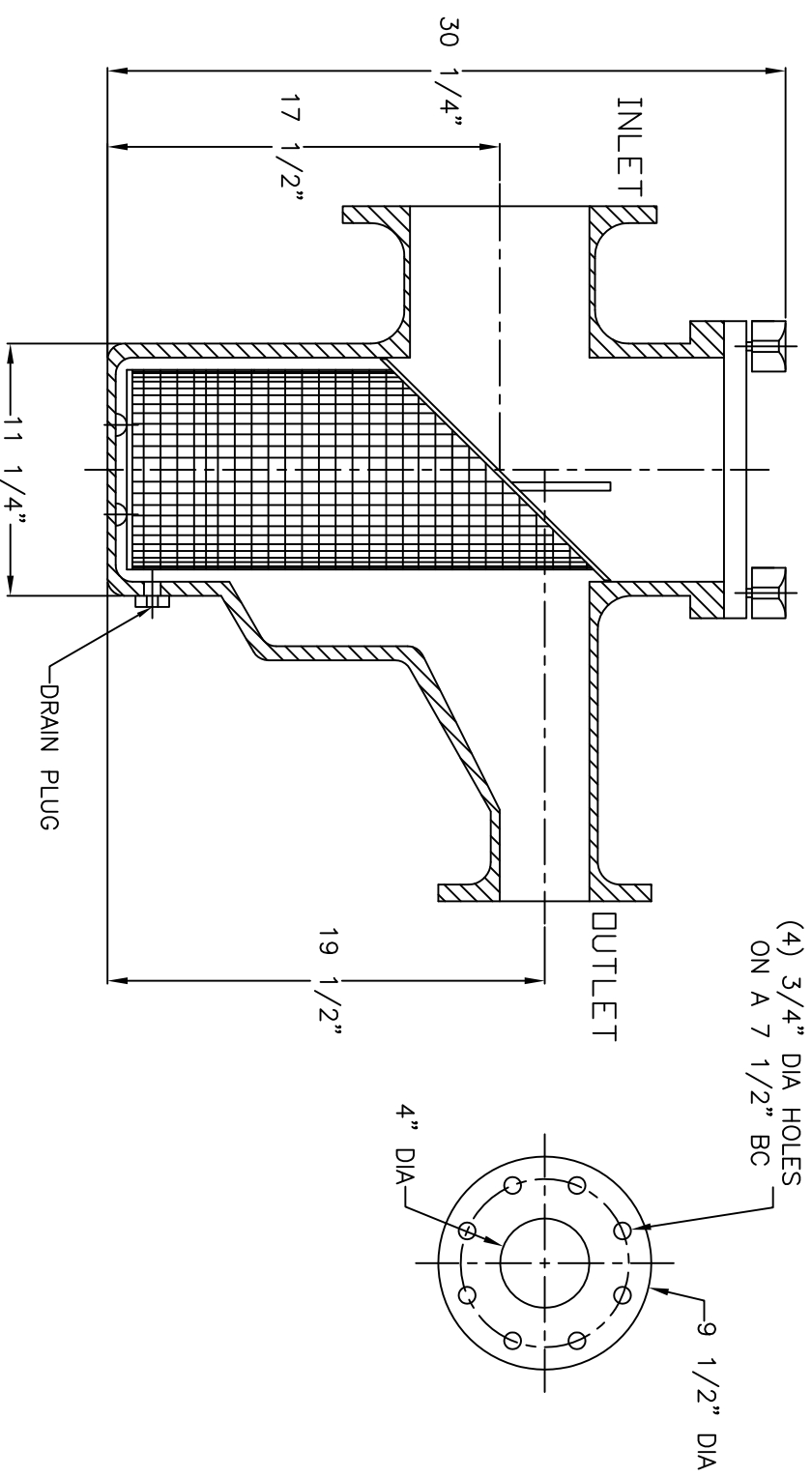

CERTIFIED FOR PRODUCTION

BY: \_\_\_\_\_ DATE: \_\_\_\_\_  
MER-MADE, INC.

THIS DRAWING CONTAINS INFORMATION PROPRIETARY TO MER-MADE FILTER INCORPORATED. IT IS SLIGHTLY IN CONFIDENCE AND IS TO BE RETURNED UPON THE PURPOSE FOR WHICH IT IS FURNISHED AND IS TO BE DESTROYED UPON THE TRANSMISSION DISCUSSED OR USED OTHERWISE IN WHOLE OR IN PART WITHOUT THE WRITTEN AUTHORIZATION OF MER-MADE FILTER INCORPORATED.

TOLERANCES UNLESS OTHERWISE SPECIFIED

MACHINED DIMENSIONS:

X.X	±.020	FINISH: 125/
X.XX	±.010	ANGLES: ±.2°
X.XXX	±.005	RADI: ±.03

FRACTIONAL DIMENSIONS:

1/X ± 1/8

REMOVE ALL BURRS AND BREAK ALL SHARP EDGES: .016 x 45°

REV	DESCRIPTION	DATE	SCALE:	NTS	DATE:	12/11/17	Sheet:	1	OF	1	REV
											RO

**MER-MADE**

PO BOX 306  
DENMARK, SC 29042  
P:803-793-4263 F:803-793-4265

8" X 4" FO SERIES ECCENTRIC  
REDUCING BASKET STRAINER

SIZE: B  
DWN BY: SUV  
CHK BY: M-0117  
DWG NO. M-0117