

NOTES

- 1. STRAINER BODY: FIBERGLASS CONSTRUCTION USING ISOPHTHALIC POLYESTER RESIN AND A .100" THK. CORROSION LINER USING ONE LAYER C GLASS AND TWO LAYERS CHOPPED STRAND MAT.
- 2. LID: CLEAR ACRYLIC
- 3. TOGGLE BOLTS: STAINLESS STEEL
- 4. HAND KNOBS: ABS WITH BRASS INSERTS
- 5. O-RING: ETHYLENE PROPYLENE
- 6. BASKET: 316 STAINLESS STEEL WEDGE WIRE, 3/16" SQ. OPENING

INLET AND OUTLET FLANGES SHALL HAVE 150# ANSI STANDARD DRILL PATTERNS

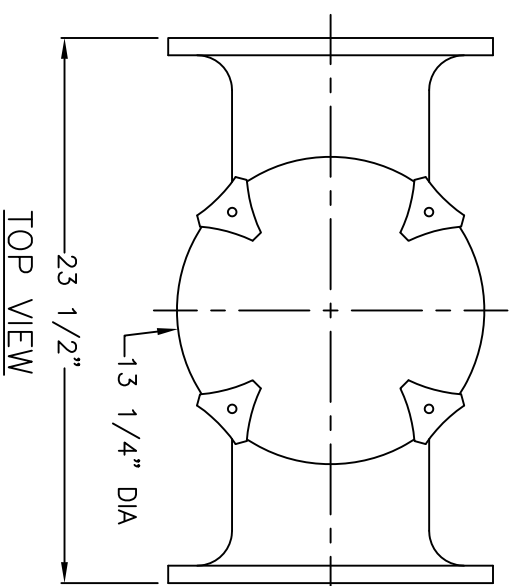

TOP VIEW

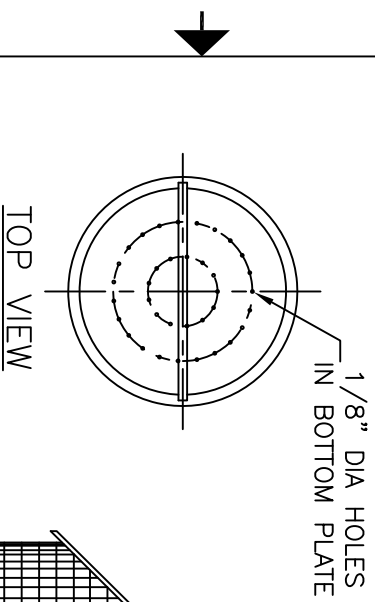

TOP VIEW

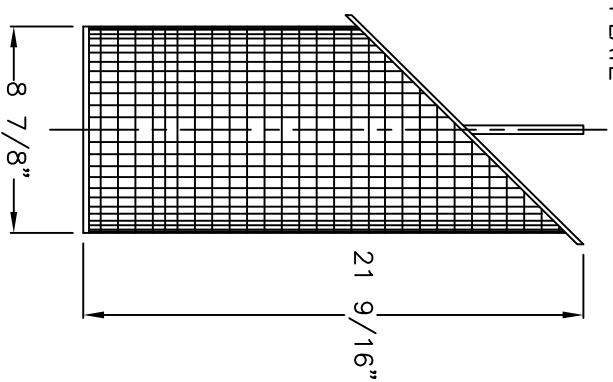

BASKET DETAIL

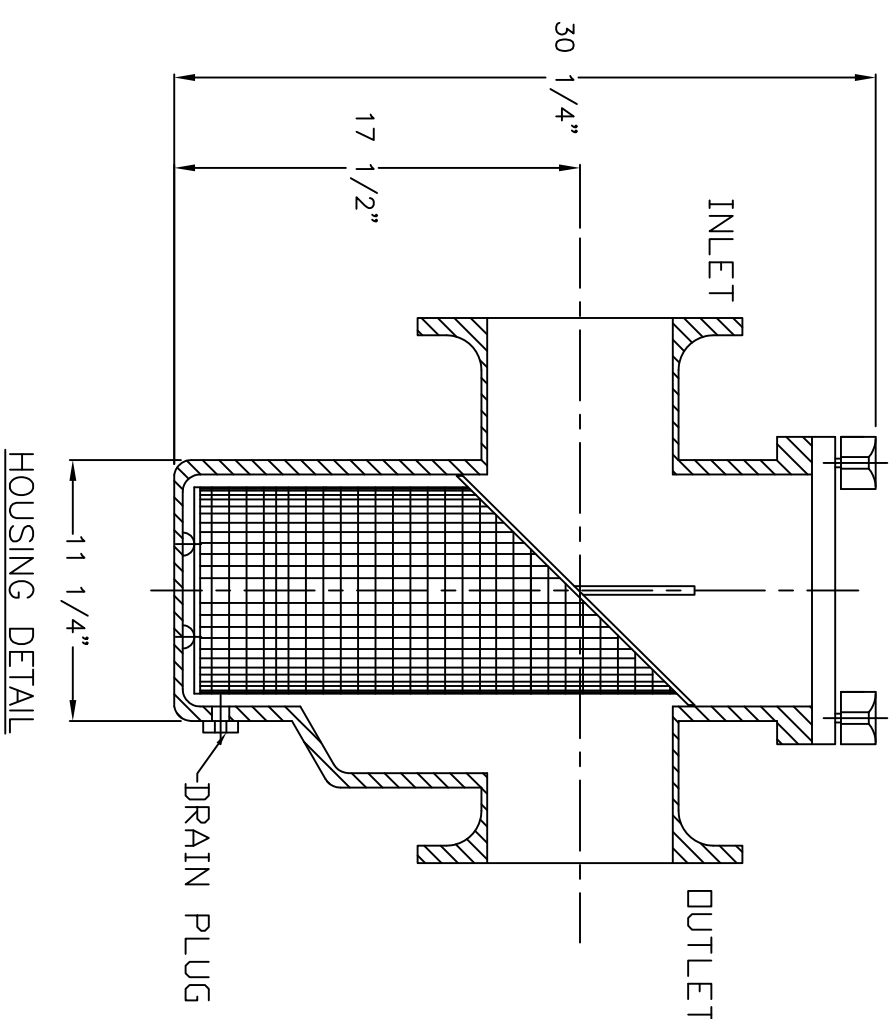

HOUSING DETAIL

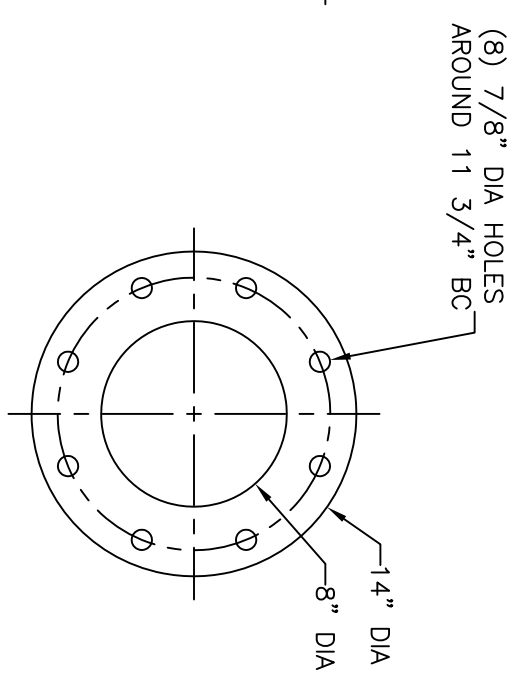

(8) 7/8" DIA HOLES AROUND 11 3/4" BC

CERTIFIED FOR PRODUCTION

BY: _____ DATE: _____

MER-MADE, INC.

THIS DRAWING CONTAINS INFORMATION PROPRIETARY TO MER-MADE FILTER INCORPORATED. IT IS SLIGHTLY IN CONFIDENCE AND IS TO BE RETURNED UPON THE PURPOSE FOR WHICH IT IS FURNISHED AND IS TO BE USED SOLELY FOR THE TRANSPORTATION AND USE OF THE PARTS AND COMPONENTS OF THE EQUIPMENT TRANSMITTED DISCUSSED OR USED THEREIN IN WHOLE OR IN PART WITHOUT THE WRITTEN AUTHORIZATION OF MER-MADE FILTER INCORPORATED.

TOLERANCES UNLESS OTHERWISE SPECIFIED

MACHINED DIMENSIONS:

X.X	±.020	FINISH:	125/
X.XX	±.010	ANGLES:	±.2
X.XXX	±.005	RADII:	±.03

FRACTIONAL DIMENSIONS:

1/X ± 1/8

REMOVE ALL BURRS AND BREAK ALL SHARP EDGES: .016 x 45°

REV	DESCRIPTION	DATE	SCALE	NTS	DATE	Sheet	OF	REV



PO BOX 306
DENMARK, SC 29042
P:803-793-4263 F:803-793-4265

8" FO SERIES BASKET STRAINER

SIZE: B
DWN BY: SUV
CHK BY: _____
DWG NO. M-0082

SCALE: NTS
DATE: 10/20/17
Sheet: 1 OF 1